

# ENVIRONMENTAL REMEDIATION AIR CLEANER

## M68P - PORTABLE HEPA AIR CLEANER

*The M68P is ideal for remediation or construction projects where control of migratory particulate is required. With airflows of up to 2000 CFM this unit can create a negative pressure environment\* while the true HEPA controls the particulate to 99.97% efficiency.*



\* Outlet duct required for negative pressure mode.

### SPECIFICATIONS:

- Cabinet: 16-gauge steel cabinet with a chemical resistant baked enamel, ivory texture coated finish.
- Power Input: 208-240 VAC, 1 Phase, 9 amps
- Motor: 2 HP maintenance-free sealed ball bearings and thermally protected. Adjustable motor sheave allows for field airflow adjustments.
- Blower: Forward curved, ball bearing, belt driven centrifugal blower
- Airflow: Up to 2000 cfm
- Filtration: Pre-filter - 24" x 24" x 4" 35% pleated media  
Primary - 24" x 24" x 12" HEPA 99.97% certified efficiency at 0.3 microns
- Casters: 5" Swivel
- Handle: High Impact Plastic
- Dirty Filter Gage: Water monometer tells when filter needs to be changed.

### Options:

45 pound carbon module for removing VOCs.

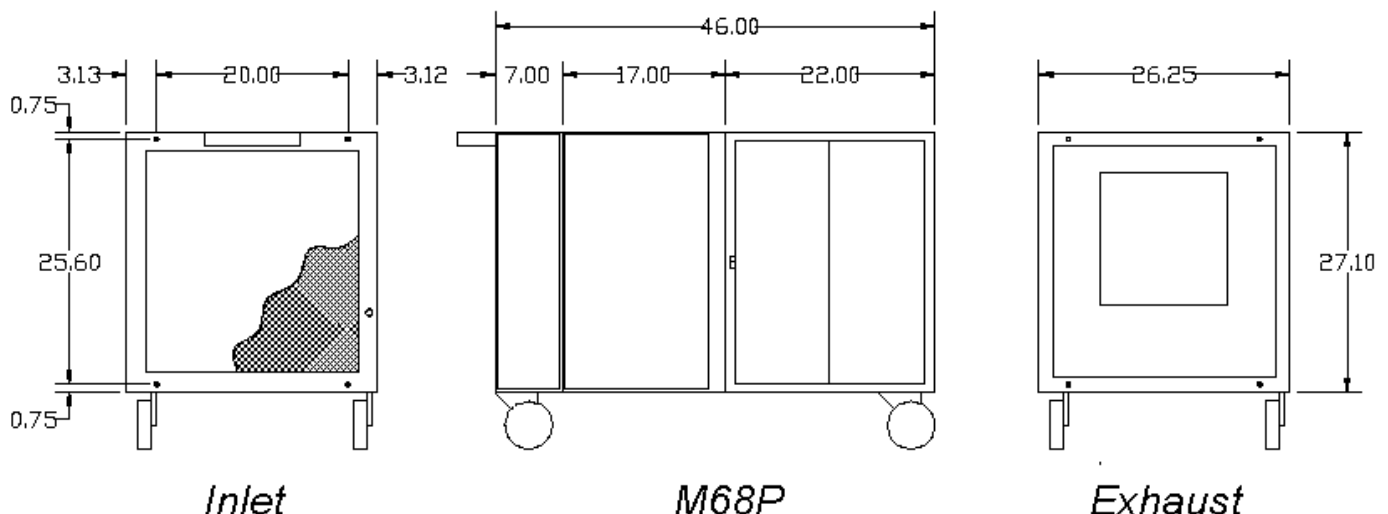

For information:  
**BERRIMAN ASSOCIATES**  
[www.berriman.com](http://www.berriman.com)  
1-800-480-3630

Manufacturer has a policy of continuing product improvement and reserves the right to make changes in design and specification without notice.

# 6000V & 7500 AIRWASH CARTS



6000V Cart

7500 Cart

An Amaircare Airwash system will effectively clean and circulate air throughout your space.

### Three-Stage Filtration

Removes particulates, V.O.C.'s and odours using HEPA filters and carbon.

### Easy/Change Filters

Quick access panels allow for easy maintenance.

### Durable Metal Cabinet

Greater protection for internal components and filter systems.

### No Harmful Production of By Products

Some systems can produce ozone which has found to be harmful to human health.

### Highly Efficient

The AirWash is 99.97% efficient on air borne particles over 0.3 microns (1/25,000 of an inch).

### Safe

The AirWash can safely be used while people are present.. Easy to use, you simply plug it in and turn it on.

### Rugged

The AirWash solid metal construction and heavy duty wheels are built for years of trouble free operation in the most demanding of environments.

### Amaircare Certified

Airwash will produce "maximum indoor air quality" and is suitable for people suffering from chemical sensitivities, asthma or allergies.

### Versatile

The AirWash can be used in hotel rooms, when cleaning or vacuuming floors, in print shops or anywhere that elevated V.O.C.'s, particulate or odors are a problem.

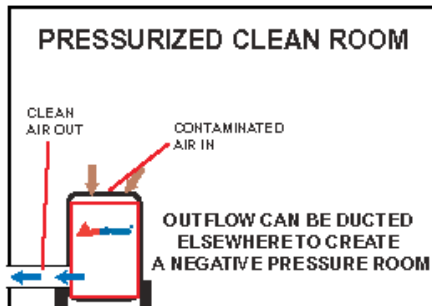

### PREFILTER DOOR

### FOAM PRE-FILTER (STAGE 1)

### H.E.P.A. FILTER (STAGE 2)

- REMOVES 99.97% OF PARTICULATES FROM 0.3 MICRONS
- 1.25 SQ. FT SURFACE AREA
- LASTS UP TO 5 YEARS

### V.O.C. FILTER (STAGE 3)

### PROTECTIVE SCREEN FOR H.E.P.A. FILTER

### POWERFUL, EFFICIENT MOTOR/FAN

- C.S.A. AND N.T.R.L. (U.L.) APPROVED

### METAL CABINET

- DURABLE
- EMITS NO TOXINS

### METAL CART

- RUGGED CONSTRUCTION FOR MOBILE DURABILITY

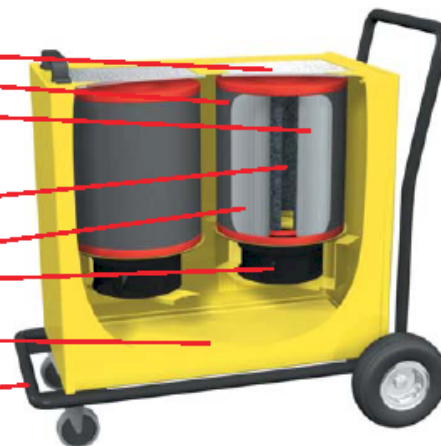

## Specifications (All Models)

### CLASSIFICATION

- Central H.E.P.A. (High Efficiency Particulate Air) 100% Sealed Air Cleaning Device
- U.L. and C.S.A. approved

MATERIALS: 18 gauge satin coat steel

FINISH: Powder coated baked enamel

COLORS: Yellow

### MOTOR/FAN

- Thermally protected Class "B" insulated motor
- Designed for continuous operation.
- Run tested for 50,000 hours
- Service: 120 Volt, 60 Hz or 200/230 Volt, 50/60 Hz

CONTROL: On/Off Switch

### FILTER LIFE

- Stage 1: Foam Filter: 6-12 months
- Stage 2: H.E.P.A. Filter: 2-5 years
- Stage 3: V.O.C. Filter: 6-12 months

### INTAKE:

Alum pre filter on access door can be removed and steam cleaned.

### OUTFLOW:

8" duct fitting(s) on side

## 6000V Cart

DIMENSIONS: 27" W 26"L 38"H

H.E.P.A. SURFACE AREA: 100 sq.ft.

WEIGHT: 92 lbs.

AIR FLOW (C.F.M.): 600

POWER CONSUMPTION: 160 Watts

## 7500 Cart

DIMENSIONS: 27" W 40"L 38"H

H.E.P.A. SURFACE AREA: 200 sq.ft.

WEIGHT: 118 lbs.

AIR FLOW (C.F.M.): 1000

POWER CONSUMPTION: 320 Watts

For further information:  
**BERRIMAN ASSOCIATES**  
 1-800-480-3630  
[www.berriman.com](http://www.berriman.com)

*Cleaning the air you breathe.*

Further information:  
BERRIMAN ASSOCIATES  
1-800-480-3630  
www.berriman.com

More Filtration. More Features.  
Better Value. Guaranteed !

## Air Rhino 2000 [ Dual Purpose 2 Speed ]

**Flexible, cost-effective system designed for Restoration, Renovation  
and Indoor Construction**

With Interchangeable Carbon\* for Odor & Chemical Control, or Alternative HEPA Filtration for Particulates.

\* 100 lb. canister of activated granular carbon for mitigation of VOC, Chemicals, Gases, and Odors

Cleans up chemicals, odors, gases, mold & fungal mycotoxins  
40 Specialty blends of carbon available for specific chemical problems or general all purpose carbon that can adsorb over 4,000 hazardous chemicals.

### High powered Air Rhino

- 2 speed motor blower, 1000 CFM purifying power
- 4 Handles and 4 industrial wheels (2 swivel, 2 straight). Easy to maneuver
- Dimensions: 26 1/2" x 26 1/2" x 37"
- 18 gauge, polished galvanized steel body for durability
- Industrial ball bearing wheels
- DOP tested
- 12" hose attachment for Negative Air

### Filters for chemical gases and odors

- 100 lb canister of granular carbon
- Quick change (1/2 minute) pre-filter, 24" x 24" x 1"
- Quick change (1/2 minute) dust-filter, 24" x 24" x 1"

### OR Filters for particulates and some odors

- Pressured sealed, medical grade HEPA filter, 24" x 24" x 1 1/2"
- 7 1/2 lbs. of granular carbon
- Quick change (1/2 minute) pre-filter, 24" x 24" x 1"
- Quick change (1/2 minute) dust-filter, 24" x 24" x 1"

### Options

- UV germicidal lamp, 10, 20 or 40 Watts
- Collapsible Mylar hose and hose clamps
- 18" x 24" x 37 1/2" Housing available (narrow footprint)
- Motor before filters (vertical model)
- Metal frame or gel sealed HEPA filter
- Vertical or horizontal configurations

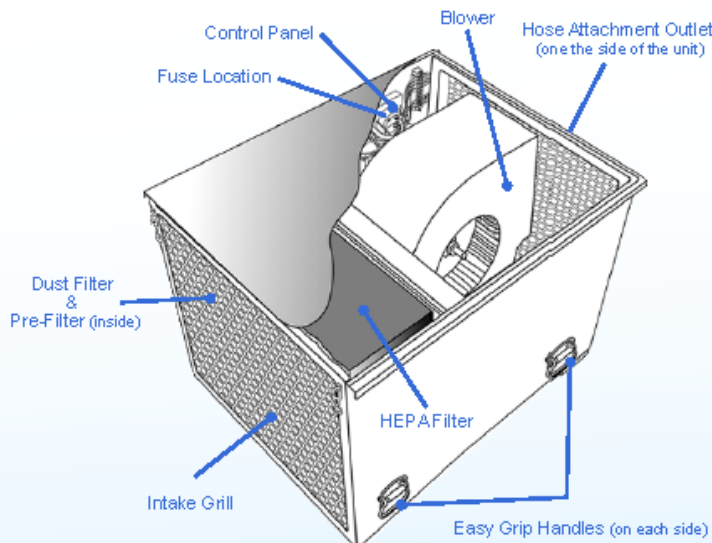

### AR 2000 Dual Purpose 2 Speed

HEPA filter, 24" x 24" x 1 1/2" & 7 1/2 lbs of carbon  
100 lb. canister of granular carbon, \$1999.98

**Use the power of 1000 CFM with Activated Carbon or HEPA filtration**

Further information: **Berriman Associates** 1-800-480-3630 [www.berriman.com](http://www.berriman.com)

Further information:  
**BERRIMAN ASSOCIATES**  
1-800-480-3630  
www.berriman.com

*Disaster Restoration - Fire, Water or Air  
Chemical, Gas, and Odor Control  
Renovation, Indoor Construction  
Mold or Asbestos  
Abatement*

# Air Rhino 2000

## Dual Purpose Variable Speed

### 1300 CFM of Air Scrubbing Power

**Flexible, cost-effective system designed for Restoration, Renovation and Indoor Construction Specialists with Interchangeable Carbon\* for Odor & Chemical Control, or alternatively, True HEPA Filtration for Particulates.**

**Cleans up chemicals, odors & gases, as well as mold & fungal mycotoxins**

\* 100 lb. canister of activated granular carbon for mitigation of Volatile Organic Compounds, Chemicals, Gases, & Odors  
40 Specialty Blends of carbon available for Specific Chemical Problems or general all purpose carbon that can adsorb over 4,000 hazardous chemicals



### High power for chemical, odor, gas or particulate removal

#### Features

- Medical grade HEPA filter, 24" x 24" x 1 1/2"
- Variable speed motor blower up to 1300 CFM purifying power, 1600 CFM Free Flow
- 7 1/2 lbs granular carbon filter
- 18 gauge, polished galvanized steel body for durability
- 4 handles and 4 industrial wheels,
- (2 swivel, 2 straight). Easy to maneuver
- Industrial ball bearing wheels
- Dimensions: 26 1/2" x 26 1/2" x 37"
- 12" Hose attachment flange for Negative Air
- Quick change (1/2 minute) pre-filter, 24" x 24" x 1"
- Quick change (1/2 minute) dust-filter, 24" x 24" x 1"
- DOP tested

#### Options

- 2000 CFM and high capacity filters (additional price of \$200)
- UV germicidal lamp, 10, 20 or 40 Watts
- Collapsible Mylar hose and hose clamps
- 18 1/2" x 24" x 37 1/2" Housing available
- 100 lb. canister of granular carbon for chemical, gas, and odor abatement
- Motor before filters (vertical model)
- Metal frame or gel sealed HEPA filter
- Horizontal and vertical configurations

#### AR 2000 Series

12" hose attachment outlet for negative air



Grill is an integral part of the unit

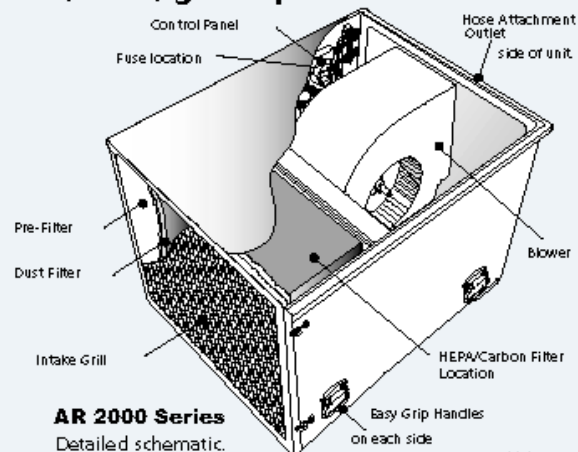

**AR 2000 Series**  
Detailed schematic.

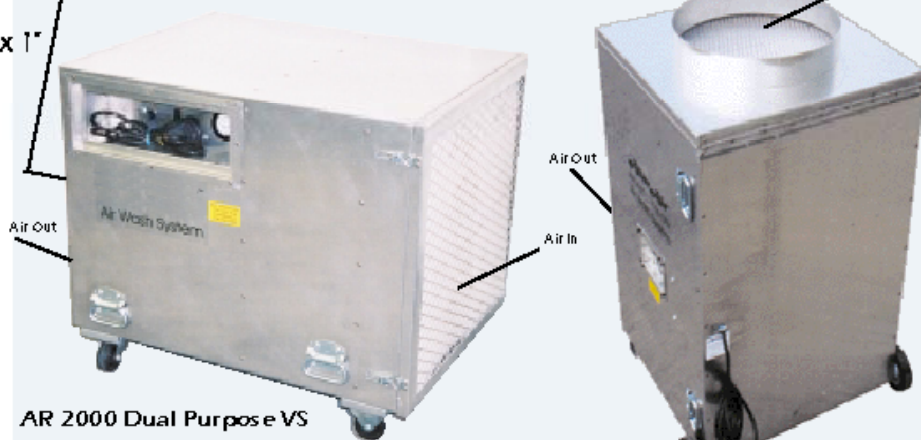

**AR 2000 Dual Purpose VS**  
Available Filtration Systems  
11 1/2" deep HEPA Filter & 7 1/2 lbs of carbon.....\$ 1499.98  
or  
100 lb. canister of granular carbon, no HEPA.....\$ 2199.98

"Narrow footprint",  
Vertical Configuration

FlyerAW2000\_DP-VS, Jan 09, 2006

Use the power of 1300 CFM with Activated Carbon or HEPA filtration

Further information: **Berriman Associates** 1-800-480-3630 [www.berriman.com](http://www.berriman.com)



### Convenient Features for Builders and Restorers:

- Completely portable
- Industrial casters
- Pressure-sensitive indicator light turns on when HEPA needs to be replaced
- Accessible 12" flange for easy ducting to create negative pressure
- Dimensions: 25" (length) x 15" (diameter)

### Filtration System:

- Option 1 ▶ **Pig EXTRACTOR HEPA:** 3" Deep HEPA filter (99.97% effective at 0.3 microns), [pre-filter](#)
- Option 2 ▶ **Pig EXTRACTOR 24:** 24 lbs of Carbon (2.5" depth), HEPA (99.97% effective at 0.3 microns), [pre-filter](#)
- Option 3 ▶ **Pig EXTRACTOR 28:** 28 lbs of Carbon (3" depth), Micro-HEPA Wrap (95% effective at 0.5 microns), [pre-filter](#)
- Option 4 ▶ **Pig EXTRACTOR 36:** 36 lbs of Carbon (3.5" depth), Micro-HEPA Wrap (95% effective at 0.5 microns), [pre-filter](#).

Documents on PDF/Sales Sheets/PIG/March, 2007

For further information:  
**BERRIMAN ASSOCIATES**  
1-800-480-3630  
www.berriman.com

**Fire and flood,  
Restoration,  
Mold spores**

# Model AW3000 Hood

**Smoke and Odor Restoration** Air Purification System

**Get 1000 CFM  
of air wash power**

**Smoke and odor damage restoration for individual items.**

40 Specialty blends of carbon available for specific chemical problems that can adsorb more than 4000 different hazardous chemicals.



## High power for particle or gas removal

- Pre-filter (quick-change) 24" x 24" x 4"
- HEPA filter 24" x 24" x 11.5"
- Motor separate from blower for easy maintenance
- 2 speed fan up to 1000 CFM cleaning power.
- Handle and 2 straight wheels.
- Dimensions: 24" x 24" x 41" - Weight: 160 lbs.
- Steel body, aluminum hood.
- 12" hose attachment option.
- 18" air inlet. (interchangeable)

## Options

- 2000 CFM.
- 100 lbs canister of granular carbon filter for chemical, gas and odor abatement.

**AW 3000 Hood**  
Can be used horizontally or vertically with interchangeable outlets.



Model AW 3000 Hood  
Vertical



30"x 30"x 36"  
detachable aluminum  
hood with 18" inlet.  
Choice of  
24" x 24" x 11.5"  
HEPA or 100 lbs.  
carbon filter  
with easy filter  
replacement.

For further information:  
**BERRIMAN ASSOCIATES**  
1-800-480-3630  
www.berriman.com

**Fire and flood,  
Restoration,  
Mold spores**

# Model 3000 Hood

Smoke and odor restoration. Air purification system

**Get 1000 CFM  
of air wash power**

**Industrial hygienists recommend high capacity Air Wash Systems**

## **Dual purpose machine with removable hood**

*Lightweight aluminum hood: easily detachable.*

*Can be used vertically with the hood for cleaning individual items, or horizontally as room cleaner.*

## **Removable hose attachments**

*Removable 12" or 18" hose attachments for negative air work.*

## **High power air moving capacity**

*Motor separate from blower for easy maintenance.*

*2 speed fan.*

*Up to 1000 CFM cleaning power.*

## **High efficiency filtering system**

*Pre-filter 24" x 24" x 4"*

*HEPA filter 24" x 24" x 12"*

*Or*

*100 lbs. granular carbon filter*

## **Easy filter change**

*Door for easy access to filters and pre-filters*

## **Convenient handling**

*Available in steel (160 lbs)*

*4 handles and wheels (2 swivel, 2 straight)*

*Dimensions: 24" x 24" x 41"*

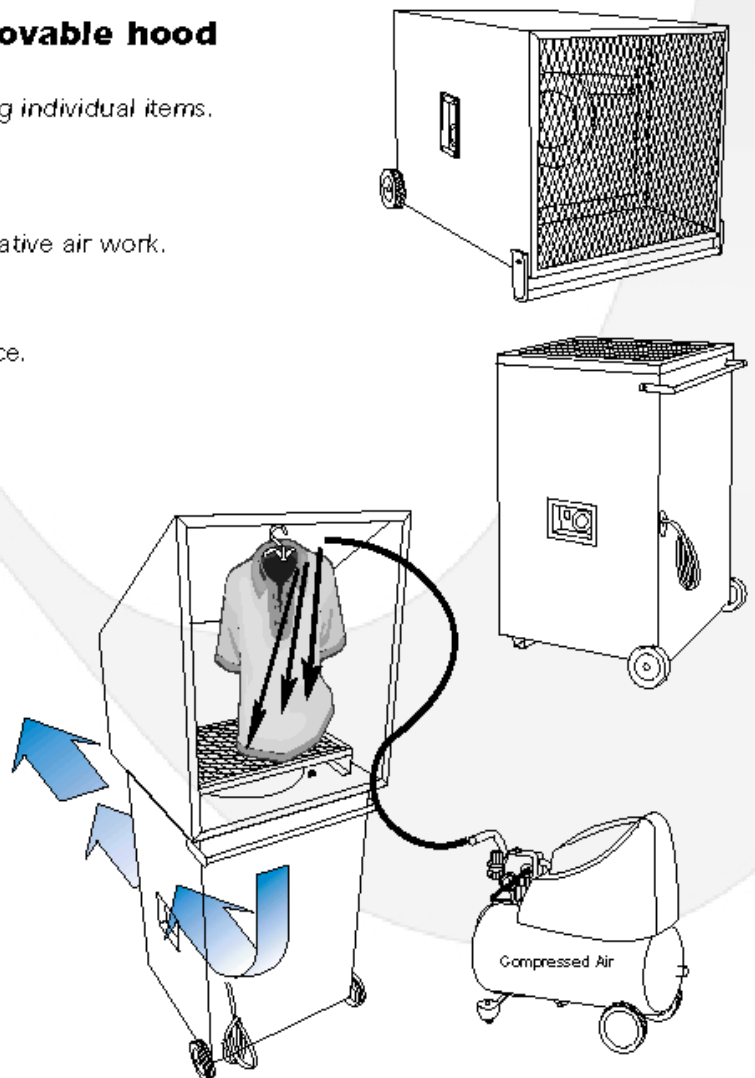

G0e45R00, AW3000Hood

**More filtration - More features - Less costly**