

INSTALLATION INSTRUCTIONS

Spot Energy Recovery Ventilator (ERV)

FV-04VE1

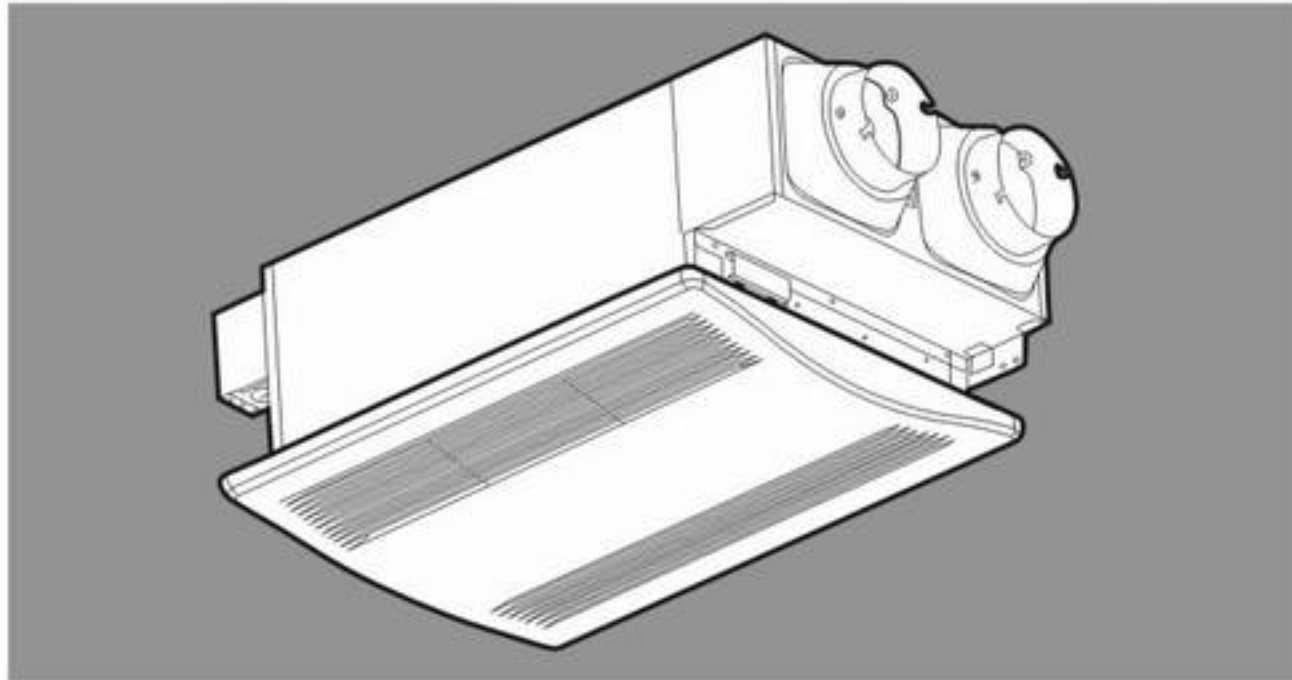

Panasonic®

READ AND SAVE THESE INSTRUCTIONS.









Please read these instructions carefully before attempting to install, operate or service the Panasonic Spot Energy Recovery Ventilator. Failure to comply with Instructions could result in personal injury and/or property damage. Please retain this booklet for future reference.

Table of Contents

Supplied Accessories.....	2
Description	2
Dimensions	3
Specifications	4
Product Operation.....	4-5
Unpacking	5
General Safety Information	5-6
Wiring Diagram	6
Recommended Zones Map	7
Wiring Connections.....	8
Installation I (Joist Mounting-I)	8-11
Installation II (Wooden Header)	11
Maintenance (Cleaning).....	12-14
Product Service	14

SUPPLIED ACCESSORIES

FV-04VE1

Part name	Appearance	Quantity
Grille		1
Suspension bracket I		1
Suspension bracket II		1
Suspension bracket III		1
Screw I (ST4.2X12)		1
Screw II (ST4.2X10)		1
Long screw (ST4.2X30)		8
Switch Label		1

DESCRIPTION

The Panasonic Spot Energy Recovery Ventilator uses two sirocco fans driven by a capacitor motor. The motor is designed to have an extended service life with reduced energy consumption. It also incorporates a thermal-cutoff for safety. The grille covering the main body is a spring-loaded, quick-release type. The exhaust air (EA) duct includes barometric damper to prevent backdrafting. And the outdoor air (OA) duct includes electric damper to prevent backdrafting and control the supply air flow.

Energy Recovery Introduction: Compared to an HRV (Heat Recovery Ventilator), the ERV (Energy Recovery Ventilator) can also transfer humidity and recover energy from that humidity. The ERV can exchange energy between the stale EA and the "fresh" OA, transferring heat and moisture into the incoming cold air in a heating climate and pre-cooling and reducing the humidity of the incoming hot air in a cooling climate. This tempering and treatment of the required ventilation air helps maintain a fresh environment even when the heating or cooling system is not operating.

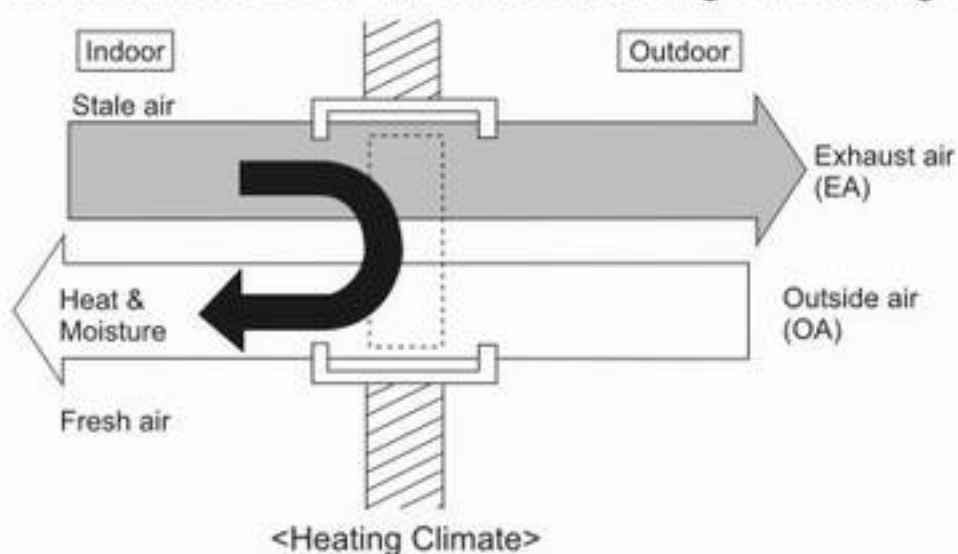

2

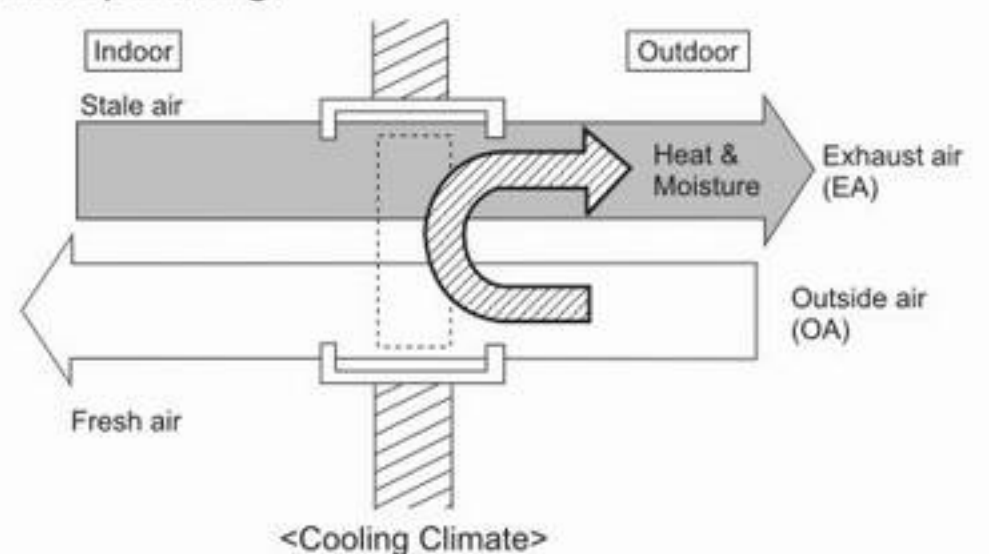

DIMENSIONS

FV-04VE1

Unit: inches(mm)

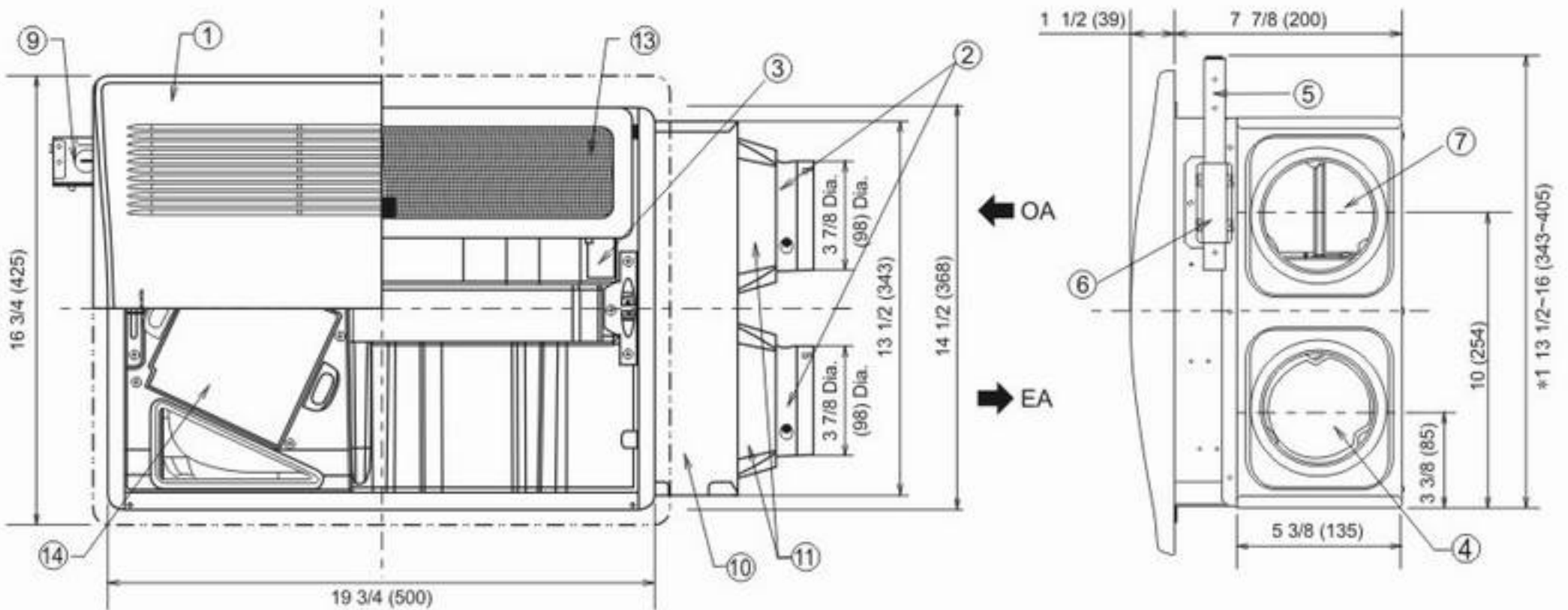
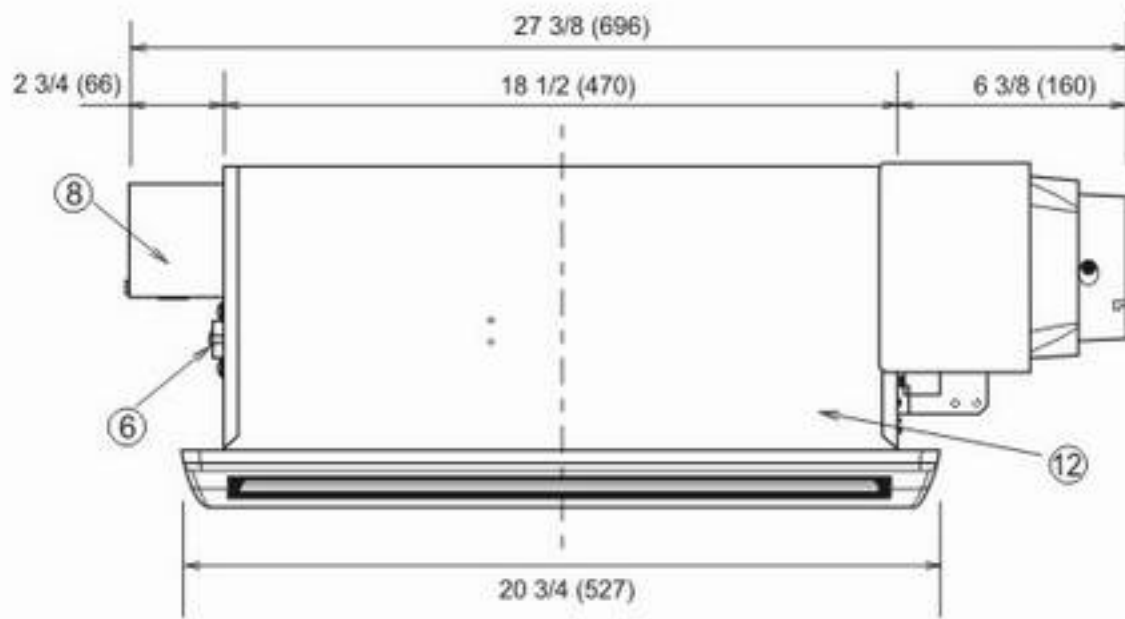

No.	Part name	No.	Part name
1	Grille	8	Junction box cover
2	Adaptor	9	Junction box
3	OA Filter	10	Damper box
4	EA Damper	11	Adaptor insulation
5	Suspension bracket I, II, III	12	Fan body
6	Bracket cover	13	RA Filter
7	OA Damper	14	Recovery core

*1 (For 16 inches O.C. joists and 19 inches O.C. joists use suspension bracket I, II & III. Please install the wooden header accordingly in the case of the 24 inches O.C. joists.)

SPECIFICATIONS

<Ventilation Performance>

• Factory setting for 40 CFM

Model	Air Direction	V	Hz	Duct	Speed	Gross Air Deliver at 0.1"WG (cfm)		Power Consumption (W) Fan Unit	Noise (sone)	Weight lb.(kg)
						Exhaust	Supply			
FV-04VE1	Exhaust & Supply	120	60	4"X2	High	40	30	24	0.8	20.5 (9.3)
					Low	20	20	21	<0.3	

• Optional setting for 20 CFM

Air Direction	V	Hz	Duct	Speed	Gross Air Deliver at 0.1"WG (cfm)		Power Consumption (W) Fan Unit	Noise (sone)
					Exhaust	Supply		
Exhaust & Supply	120	60	4"X2	High	20	20	21	<0.3
				Low	10	10	17	N/A

Selected only at installation. (Refer to Page 8)

<Energy Performance>

Mode	Supply Temperature		Net Air Flow		Total Recovery Efficiency (%)	Apparent Sensible Effectiveness (%)
	°F	°C	I/S	cfm		
Heating	32	0	14	30	N/A	66
Cooling	95	35	14	29	36	N/A

1. The testing of the ventilation performance is in general accordance with HVI procedures 915 and 916.
2. The testing of the energy performance is in accordance with CSA-C439 standard.

PRODUCT OPERATION

- ## <Main Switch>
- Power on/off for unit.
 - Turn off the Main Switch when the unit is not in use.

IMPORTANT: Unless you turn off the main switch, the unit will be in standby mode which means it is energized and will consume some electricity.
When turning on or off the main switch, push it completely to the on/off position.

<Operation Mode>

- Normal operation (Supply and exhaust)
- Defrost operation
- Exhaust operation (Exhaust only)

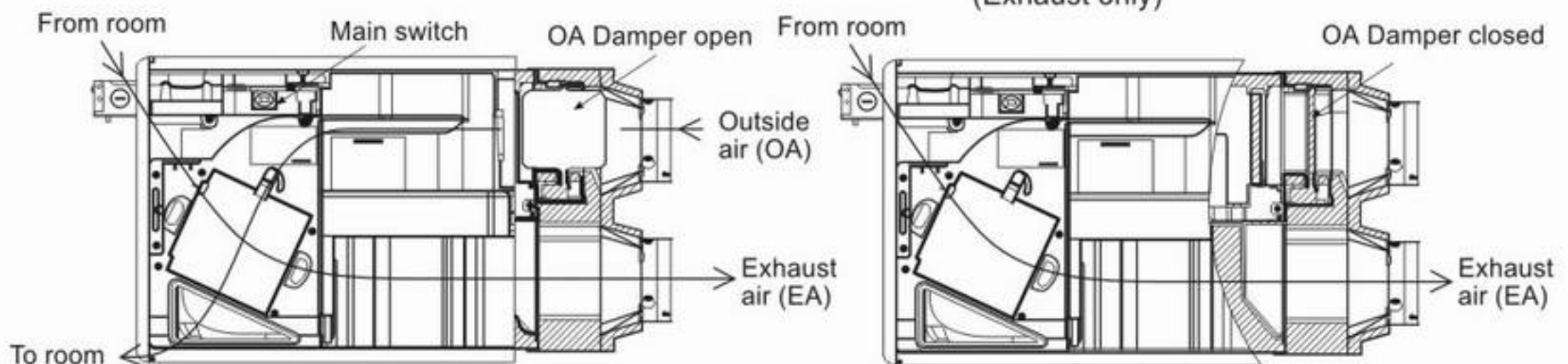

- Defrost operation
When the outside temperature is between 32°F (0°C) and 20°F (-7°C), OA Damper controls Defrost operation. Defrost operation means the damper will open for 60 min. for supply and exhaust and close for 30 min. for exhaust only.
- Exhaust operation
When the outside temperature is under 20°F (-7°C), OA Damper controls Exhaust operation. Exhaust operation means the damper will open for 10 min. to check outside temperature and close for 60 min. for exhaust only.

PRODUCT OPERATION CONTINUED

Introduction of OA Damper's movement

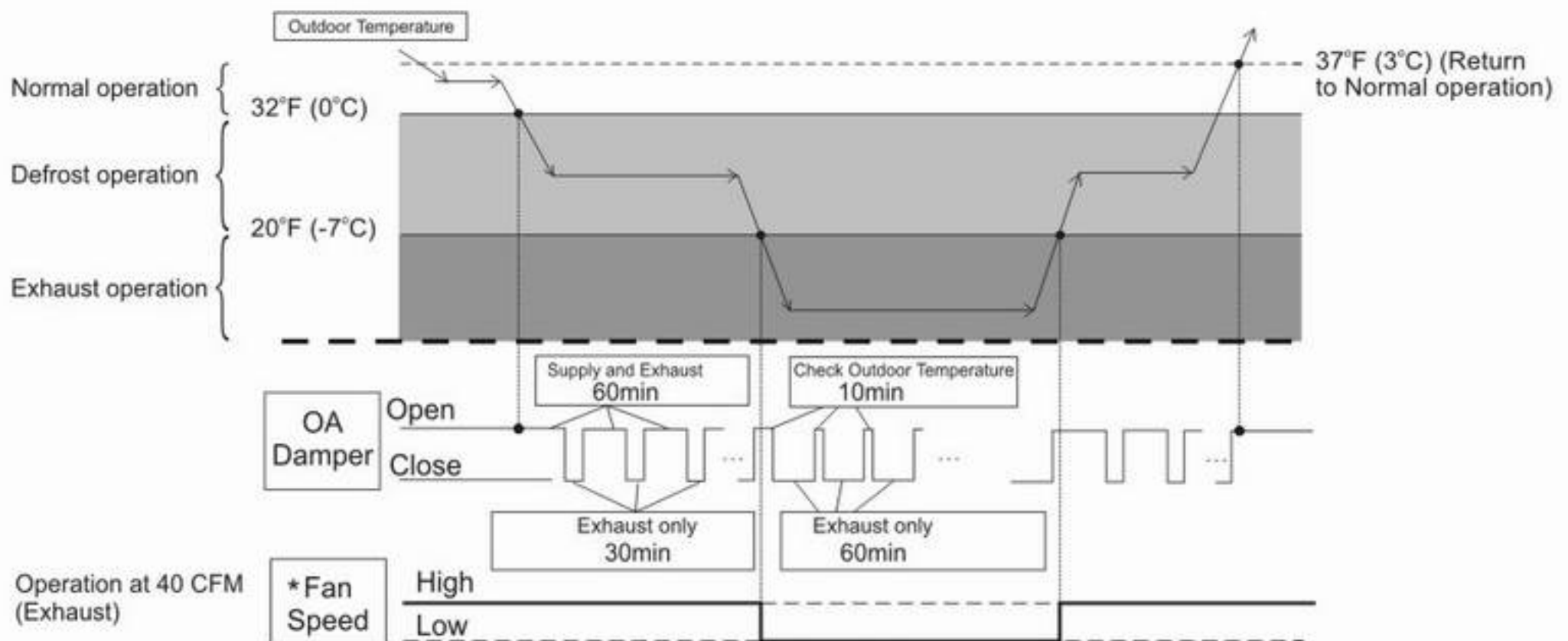

- * The High speed is automatically changed to Low speed during Exhaust operation. Another speed and optional setting (High and Low) are not changed speed during Exhaust operation.

UNPACKING

Unpack and remove unit carefully from carton.
Refer to the Supplied Accessories list to verify that all parts are presented.

GENERAL SAFETY INFORMATION

1. Do not install this ERV where air temperature may exceed 104°F (40°C).
2. Make certain that the electric service supply voltage is 120 V, 60 Hz.
3. Follow all local electrical and safety codes, as well as the National Electrical Code (NEC) and the Occupation Safety and Health Act (OSHA).
4. Always disconnect the power source before working on or near the fan, motor, fixture or junction box.
5. Protect the power cord from sharp edges, oil, grease, hot surfaces, chemicals or other objects.
6. Do not kink the power cord.
7. This unit is recommended for areas where temperature is above 20°F (-7°C). Other areas where temperature fall below 20°F (-7°C), this unit runs on exhaust only.
8. These fans are intended for residential use only.
9. Do not install the unit where ducts are configured as shown in Fig. A.

Abnormal bending



Multiple elbows



Reduction of duct



Bending near the adaptor

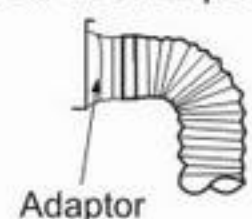

Fig. A

GENERAL SAFETY INFORMATION CONTINUED

CAUTION:

1. For general ventilating use only. Do not use to exhaust hazardous or explosive materials and vapors.
2. Do not install in cooking area or connect directly to any appliance. (Fig.B)
3. This product must be properly grounded.
4. The unit must be used in a space provided with heated and cooled air, such as a living room, dining room, bedroom, etc.
5. The ducts must be connected directly to the outside.

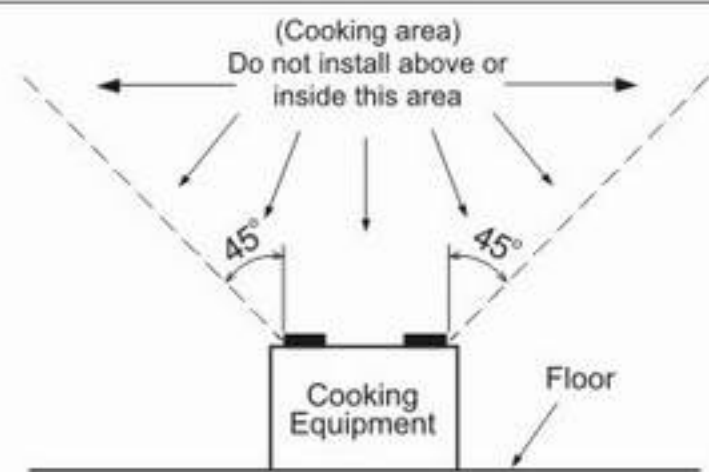

Fig. B

WARNING:

To reduce the risk of fire, electric shock or injury to persons, observe the following:

- A. Use this unit only in the manner intended by the manufacturer. If you have any questions, contact the manufacturer.
- B. Installation work and electrical wiring must be done by a qualified person(s) in accordance with all applicable codes and standards, including fire-rated construction.
- C. Sufficient air is needed for proper combustion and exhausting of gases through the flue (chimney) of fuel burning equipment to prevent backdrafting. Follow the heating equipment manufacturer's guideline and safety standards such as those published by the National Fire Protection Association (NFPA), and the American Society for Heating Refrigeration and Air Conditioning Engineers (ASHRAE) and the local code authorities.
- D. When cutting or drilling into wall or ceiling, do not damage electrical wiring and other hidden utilities.
- E. Ducted fans must always be vented to the outdoors.
- F. Solid state controls may cause harmonic distortion which can cause motor humming noise. To reduce the risk of fire or electric shock, do not use this unit with any solid-state control device.
- G. Before servicing or cleaning unit, switch power off at service panel and lock the service disconnecting means to prevent power from being switched on accidentally. When the circuit breaker panel cannot be locked, securely fasten a prominent warning device, such as a tag, to the service panel.
- H. Not to be installed in a ceiling thermally insulated to a value greater than R40. (This is required for installation in Canada only.)
- I. Never install in the area where the temperature falls below $-13^{\circ}\text{F}(-25^{\circ}\text{C})$.
- J. Never install the unit in a high humidity space, such as a bathroom, kitchen or laundry room.
- K. Install the unit in a ceiling where air temperature is above $50^{\circ}\text{F}(10^{\circ}\text{C})$ to avoid condensation in unit.

WIRING DIAGRAM

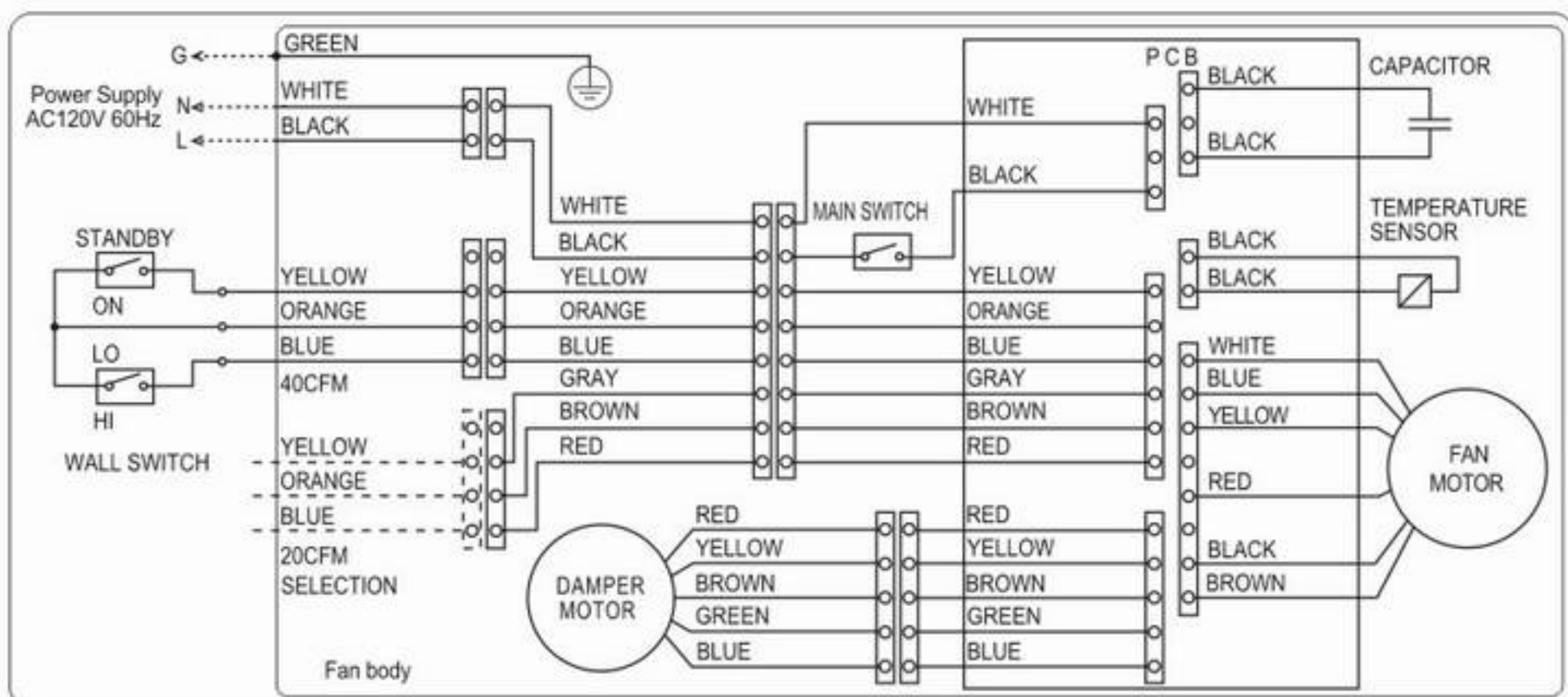





RECOMMENDED ZONES MAP

Recommended zones map

As shown on page 5, this unit has an automatic frost prevention mode, which disables the energy recovery function and allows the unit to work as a normal ventilation fan. (Fresh air will not come into the house during frost prevention mode.) The following map outlines the recommended use zones of the United States and Canada for the Panasonic Spot Energy Recovery Ventilator.



Operation Season

-  Zone A: Unit can perform optimally throughout the year.
-  Zone B: Unit can perform optimally between March through November.
-  Zone C: Unit can perform optimally between April through November.
-  Zone D: Panasonic does not recommend this unit due to extremely cold year-round weather.

Note:

This map is based on average temperature readings over 10 years from 60 major cities in North America. Actual performance may vary depending on annual temperature differences and varying altitudes.

WIRING CONNECTIONS

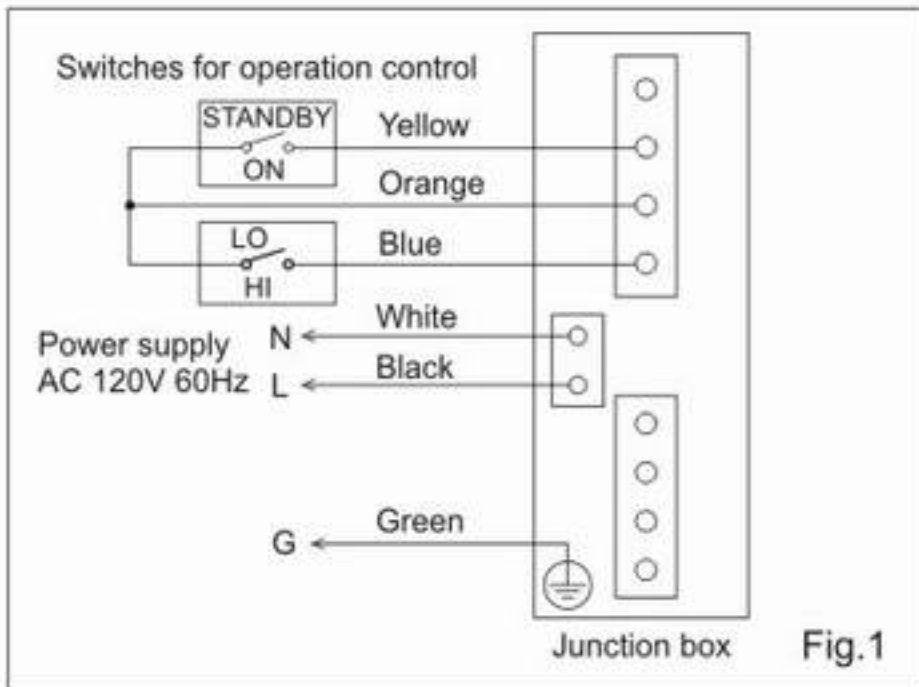

- Optional setting (20 CFM Exhaust):
If you need to change to 20/10 CFM Exhaust, move the connector to the 20 CFM Exhaust side of the receptacle.
Note: Selected only at installation (Fig.2).

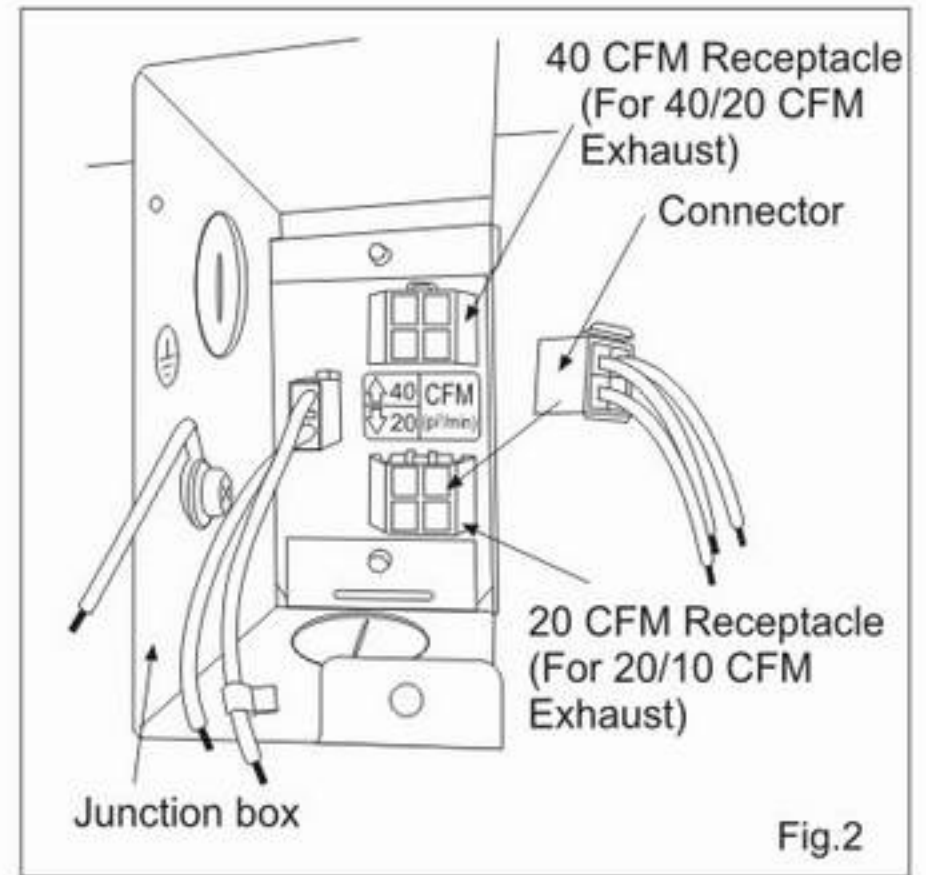

INSTALLATION I (JOIST MOUNTING-I)

IMPORTANT:

Remove the tape as shown below:

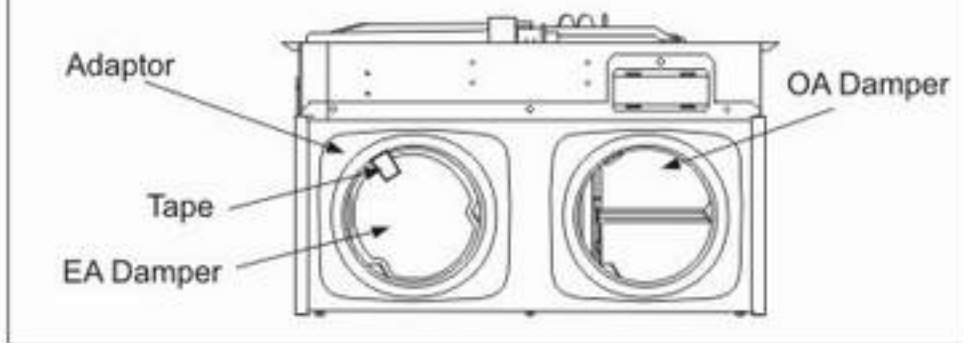

1. Insert Suspension bracket I, II, III and adjust the width to fit inside of the joists. (Fig.1)

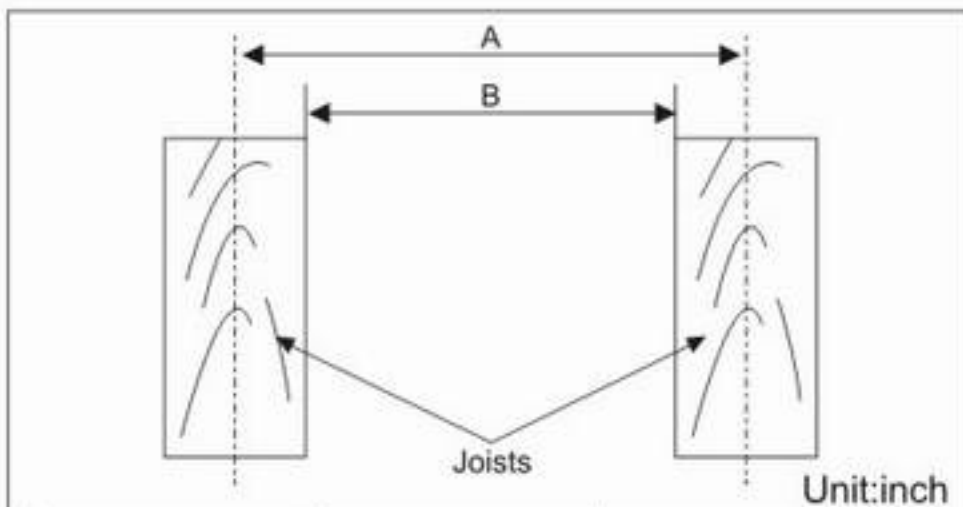

A O.C. joists	B	Insert Suspension bracket
16	14 1/2	Refer to Fig. 1
19.2	15.7	
24	22 1/2	Installation II

2. Fix screws tentatively to suspension bracket I & II, so that bracket can be adjustable.

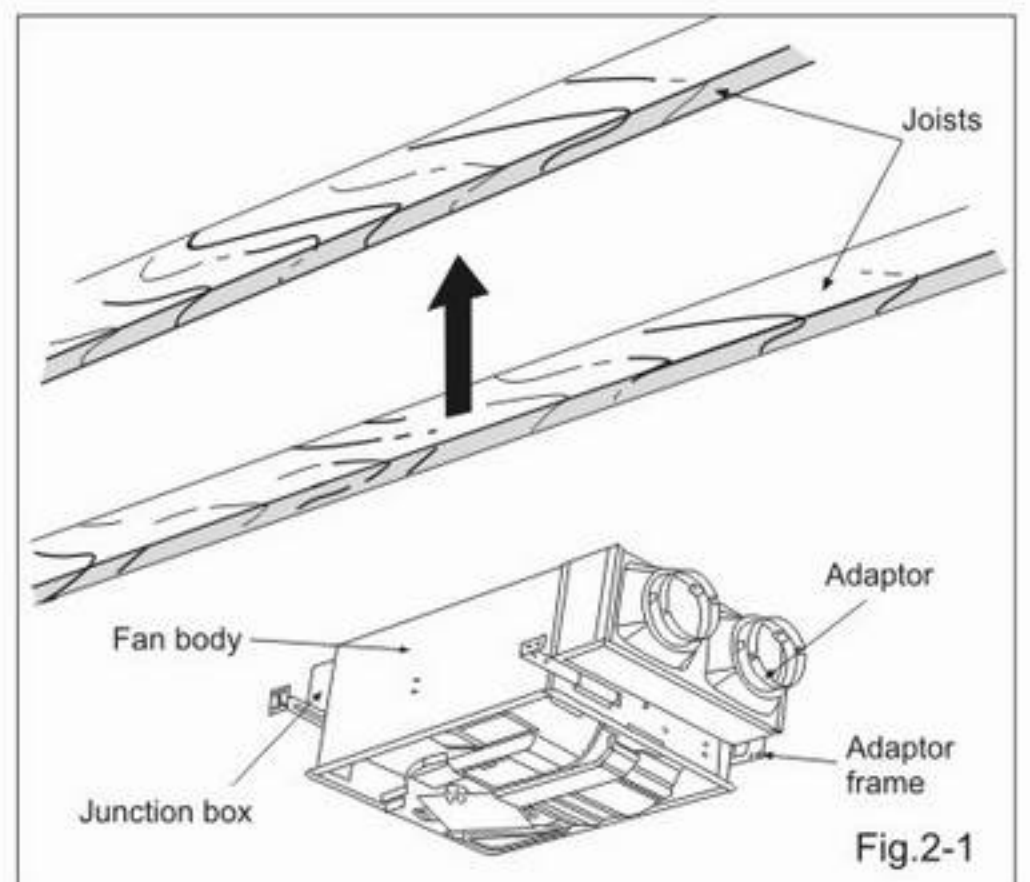
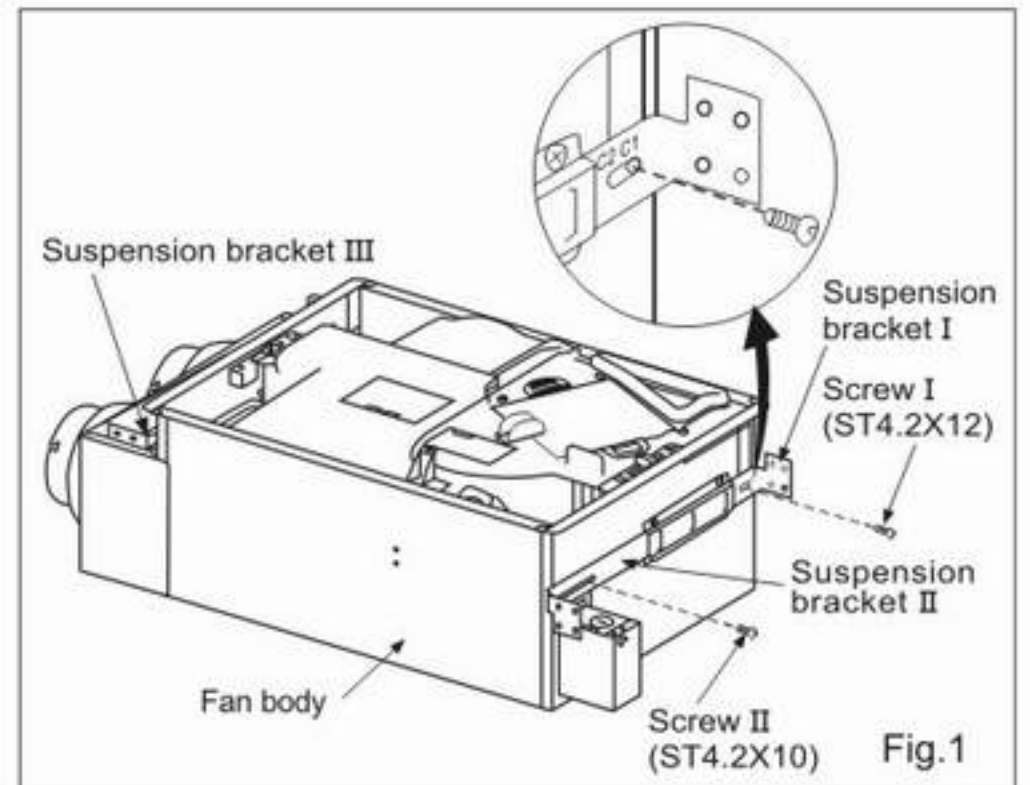

INSTALLATION I (JOIST MOUNTING-I) CONTINUED

3. Install the suspension bracket and fix the adaptor frame by using long screws (ST4.2X30) (According to Fig.2-1, Fig.2-2 & Fig.2-3 to install the product.) During installation the distance C (bottom flange) should be kept the same as the drywall thickness.

CAUTION:
If the bottom flange is not the same level as the drywall, the performance of the unit will be affected.

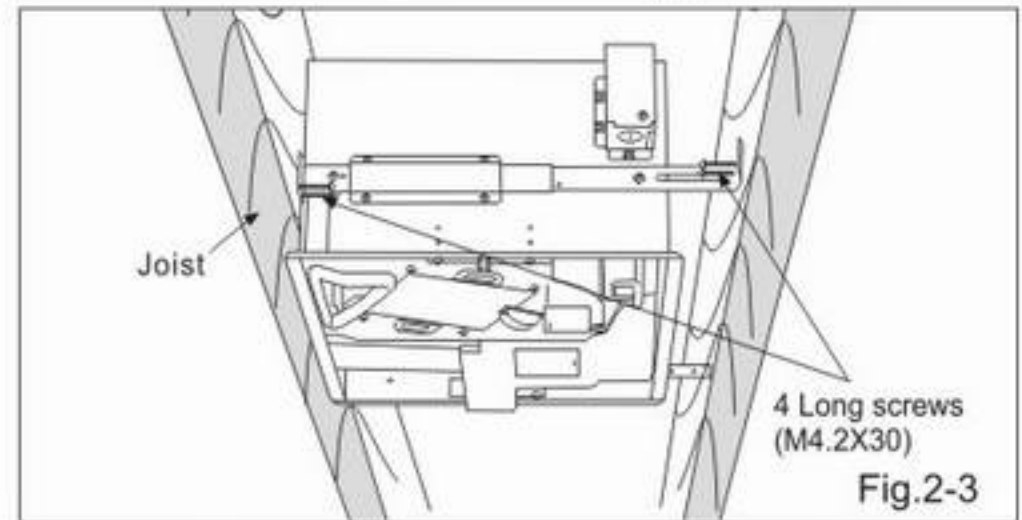
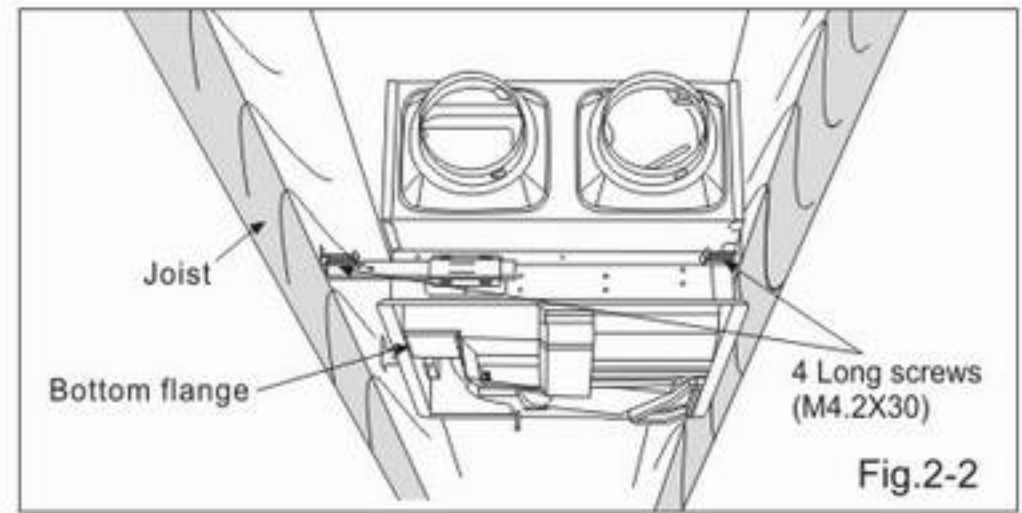
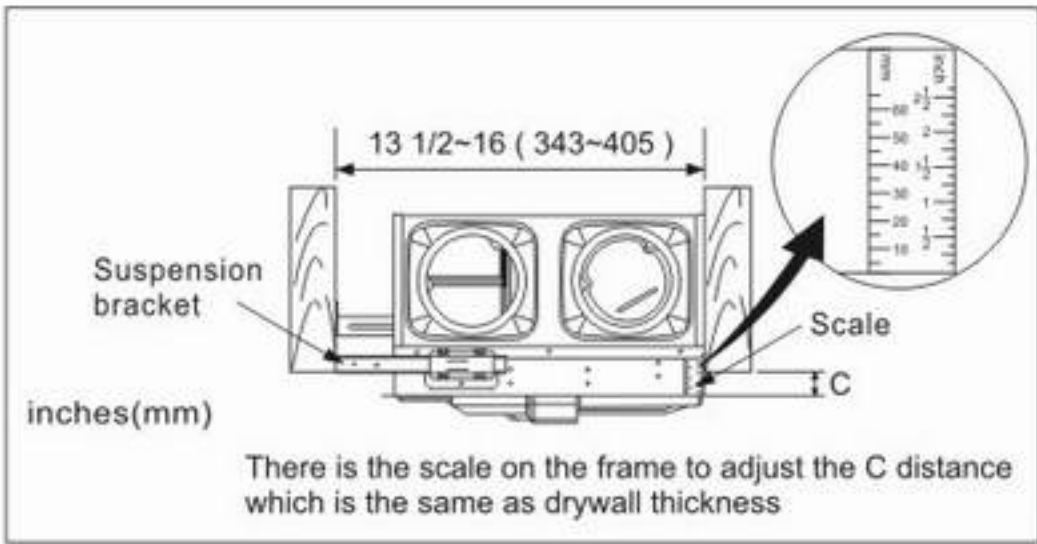

4. Fix Screw I & II on suspension bracket I and II firmly.
5. Remove Junction box cover and secure conduit or stress relief to Junction box knock-out hole. (Fig.3)
6. Refer to wiring diagram (Page 6).
Use wire nuts to connect the house power wires to the ERV wires.

CAUTION:
Mount junction box cover carefully so that the lead wires are not pinched.

Optional Air flow setting:

- Factory setting 40/20 CFM Exhaust.
- Remove Connector and change to 20 CFM Exhaust receptacle when selecting 20/10 CFM Exhaust. (Page 8)

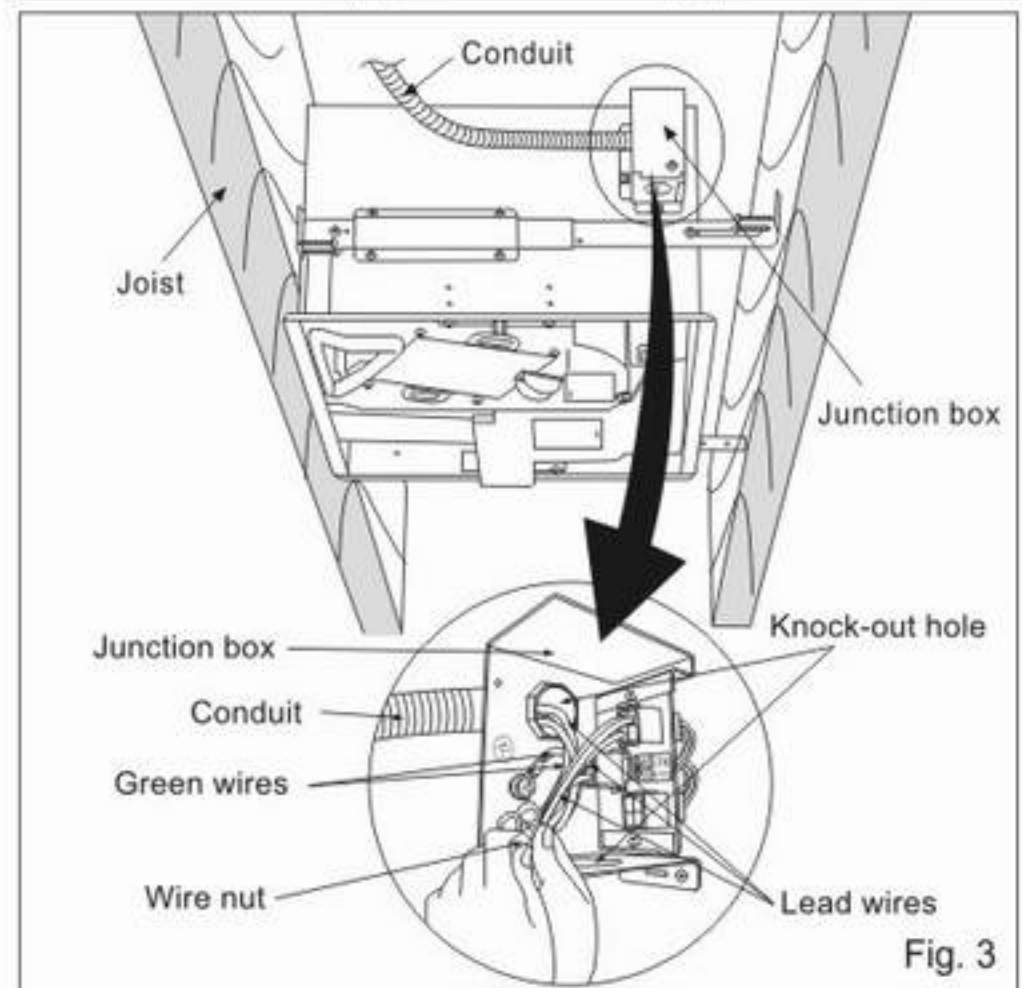

7. Install insulated ducts and secure them to adaptor with duct tape or clamps. (Fig.4-1)
8. Properly insulate the area around the fan body to minimize building heat loss and gain.
Loose fill or batt insulation can be placed directly over the fan body in the attic. Our cool-running motors do not create enough heat to require special clearance.

CAUTION:
Insulated duct should be used and sealed to adaptor to avoid the water dripping due to condensation.

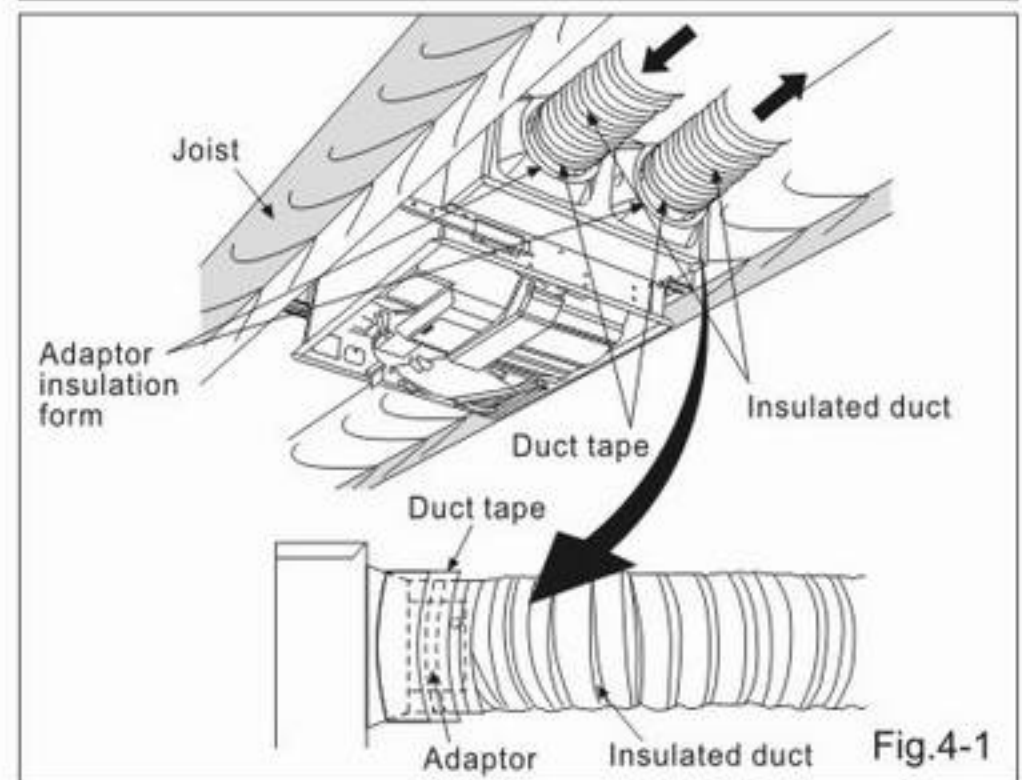

INSTALLATION I (JOIST MOUNTING-I) CONTINUED

9. Locate the intake hood and the exhaust hood at least 3' (920mm) away from each other. (Fig.4-2)

CAUTION:

The intake air side duct must be connected to the outside and at least 6' (2m) away from the exhaust of appliances such as furnace, dryer, fuel burning appliances, etc.

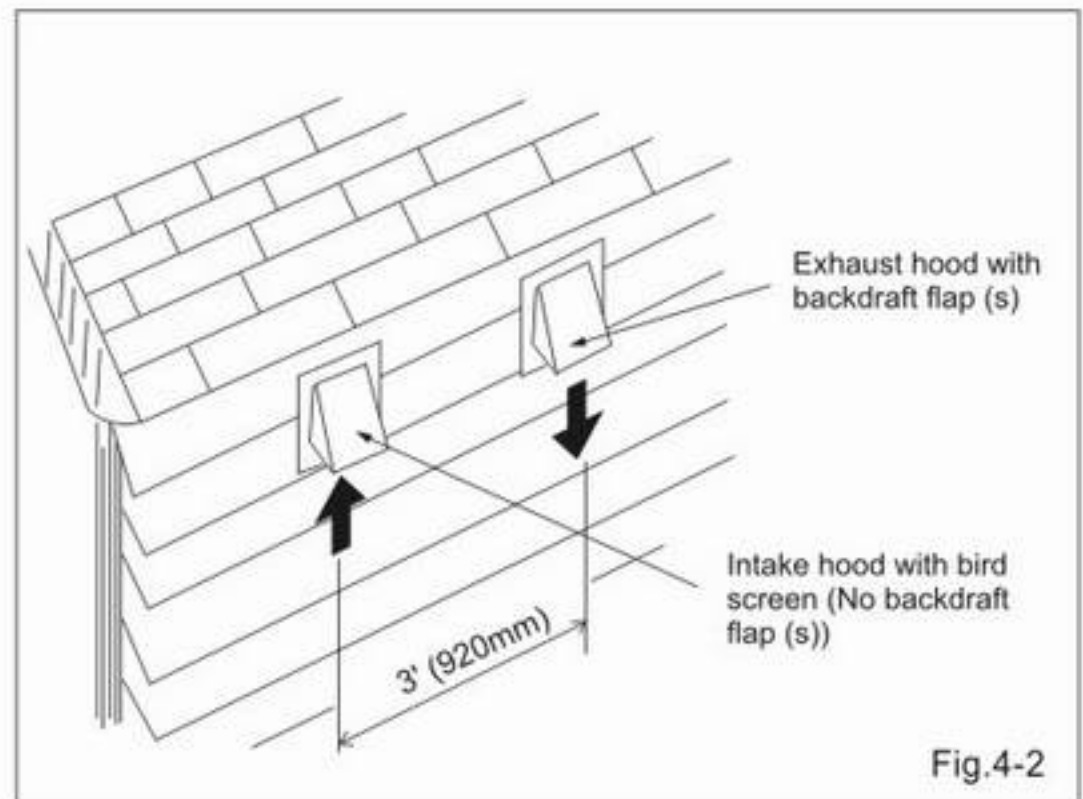

Fig.4-2

10. Finish ceiling work. Ceiling hole should be aligned with the edge of the flange. (Fig.5-1)
In attic installation, caulk the body to drywall.

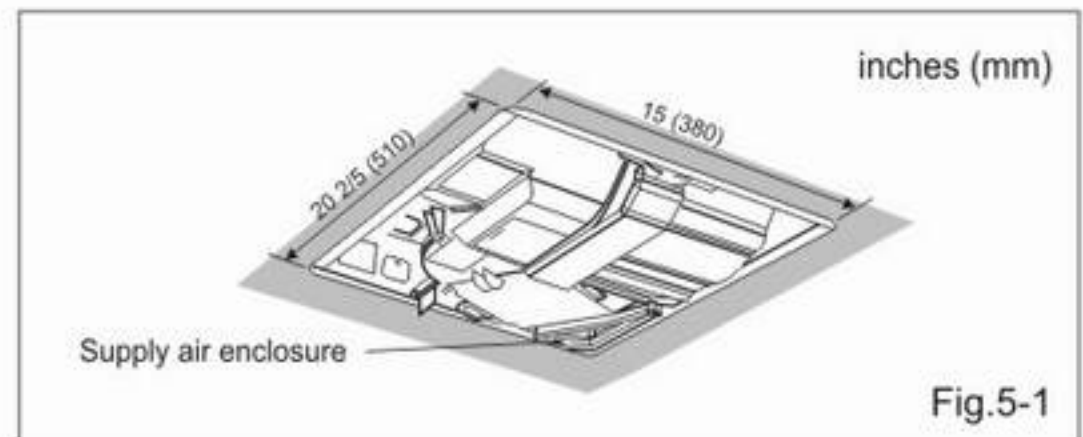

Fig.5-1

11. Turn the grille to the appropriate direction to fit the supply air side. Insert mounting springs into slots as shown and mount grille to fan body. During installation of the grille, keep the recovery core to the left and keep the RA filter in front from your position. (Fig. 5-2)

Note: If grille has a gap from the ceiling, adjust the grille position to fit the supply air enclosure on the grille with the one on the fan body and push grille. (Fig. 6-1)

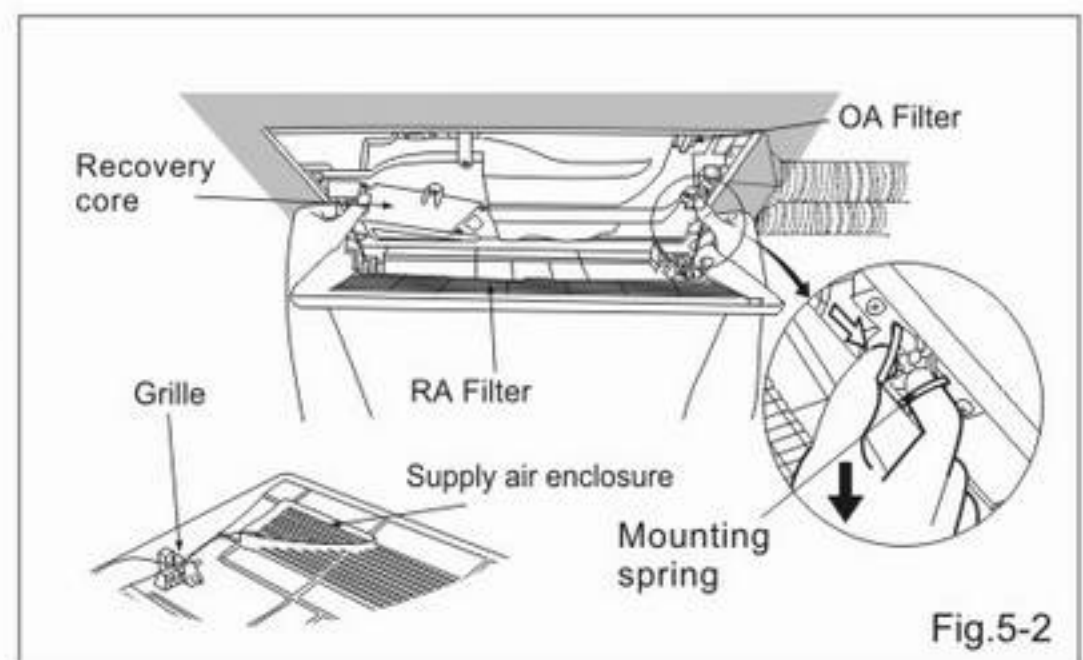

Fig.5-2

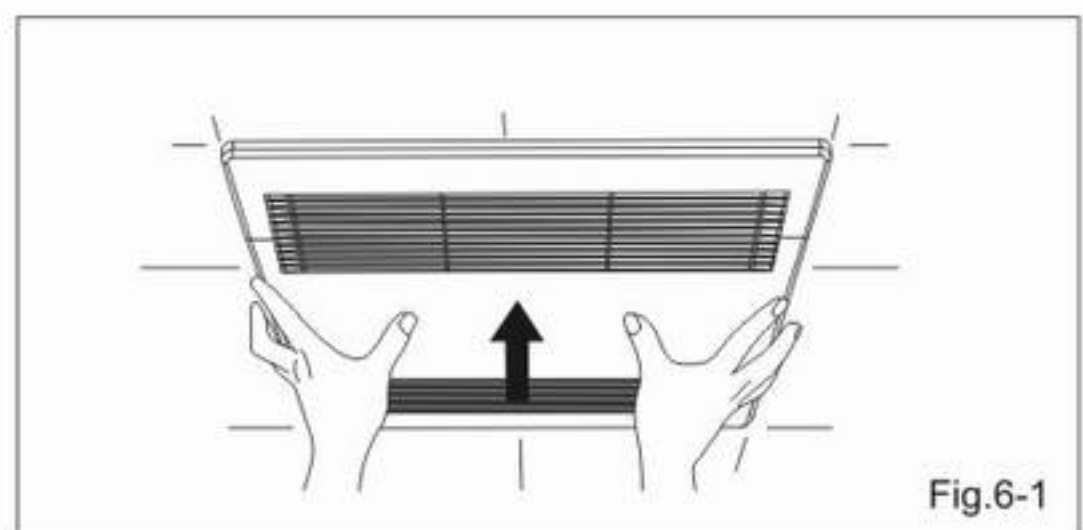
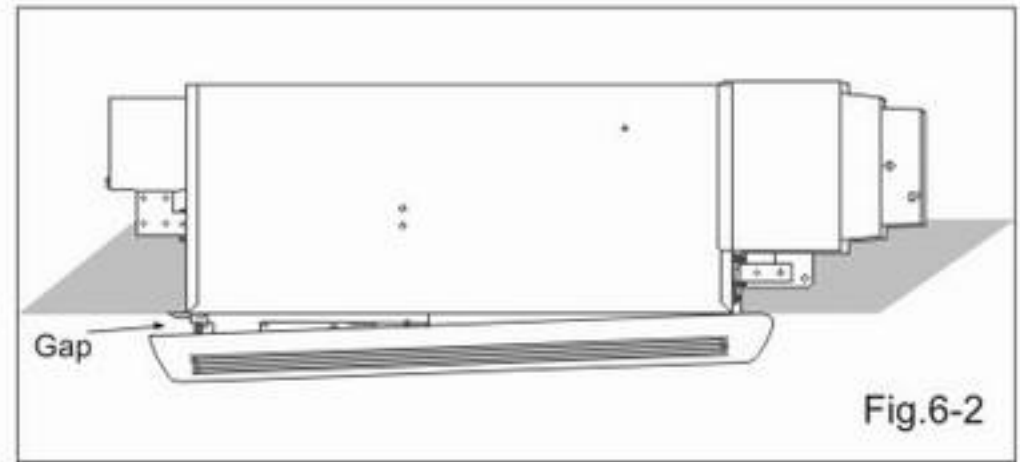

Fig.6-1

INSTALLATION I (JOIST MOUNTING-I) CONTINUED

Note:

If the grille is mounted in the opposite direction, the grille can not be fitted to the ceiling (Fig. 6-2), so then reverse the grille position and try to mount again.



[Optional]

Attach the given switch labels (in accessories) on the wall switch (not included) as shown in the diagram for clearer indication.

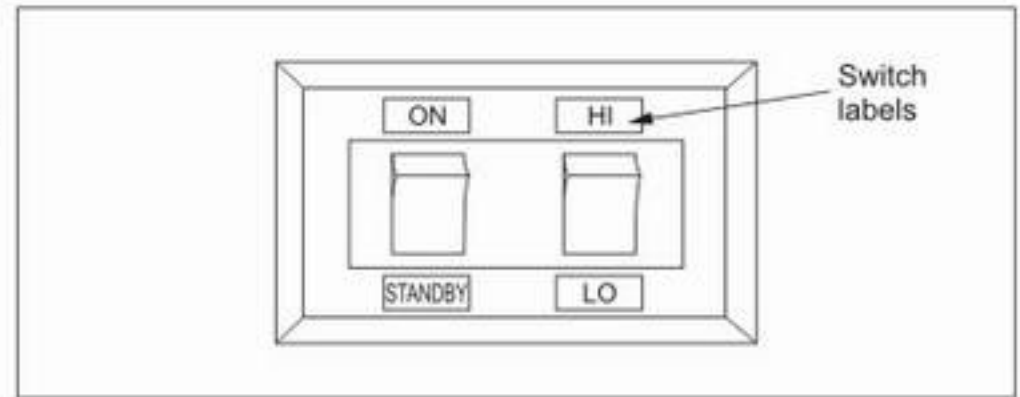

INSTALLATION II (WOODEN HEADER)

1. Install header between joists by using nails or screws. (Fig.7)
 Insert Suspension bracket I,II,III and adjust the width to fit inside of the joist and header. (Fig.1)
 Insert the fan body between joists and header. Make sure the fan body is horizontal and vertical to the joists. (Fig.7)

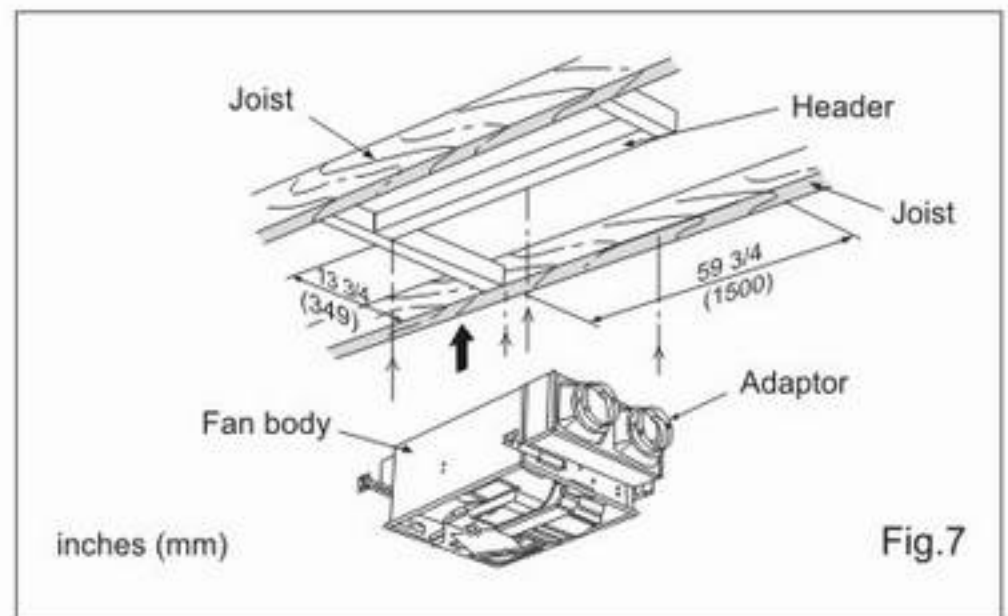

CAUTION:
 If the bottom flange is not the same level as the drywall, the performance of the unit will be affected.

2. Follow step 2 to 4 of installation I (Page 8, Page 9) to install the fan body.
3. Follow step 5 to 11 of installation I (Page 9, Page 10) to complete the installation work.

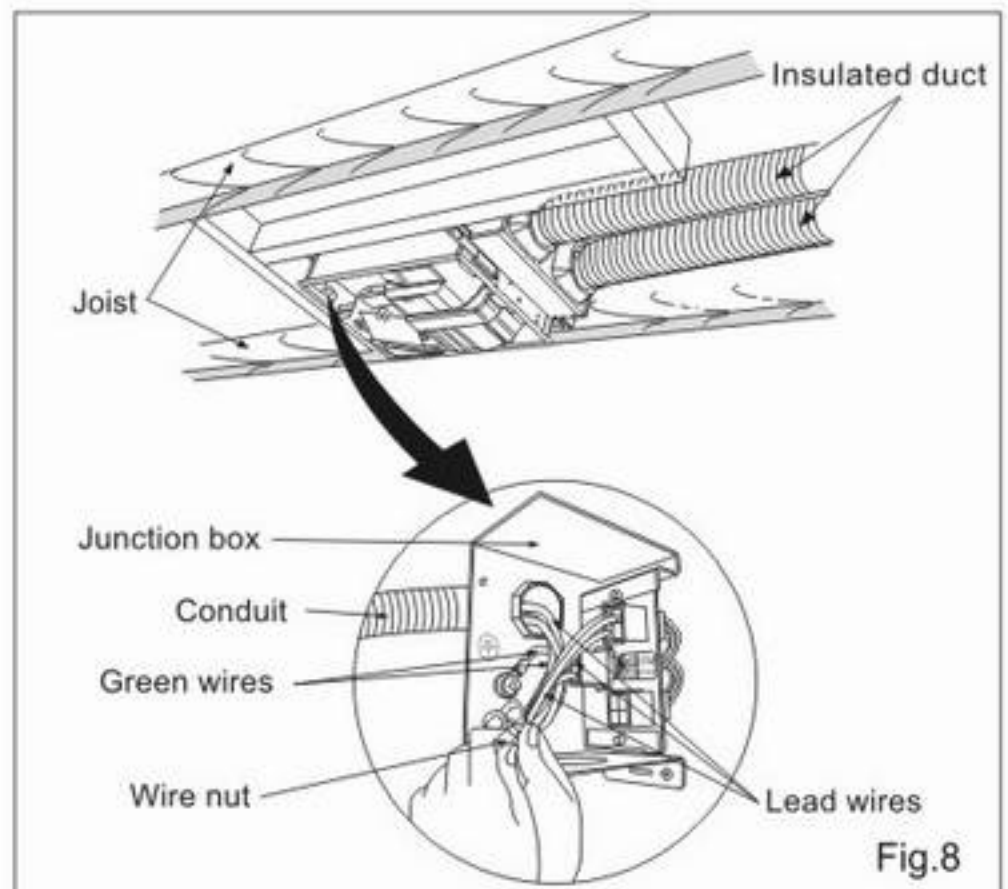

MAINTENANCE (CLEANING)

WARNING:

- Disconnect power source by switching off at service panel before working on unit.

CAUTION:

- Routine maintenance must be done every 2 or 3 months.
- Clogged filters may cause the condensation on the unit due to air flow reduction.

CAUTION:

1. Never use petrol, benzene, thinner or any other such chemicals for cleaning the ERV.
2. Do not allow water to enter motor.
3. Do not immerse resin parts in water over 60°C.

1. Remove the Grille. (Squeeze mounting spring and pull down carefully.) (Fig.10)

2. Remove the RA Filter from the Grille. (Fig.11)

3. Wash and clean Grille. (Use non-abrasive neutral kitchen detergent, wipe dry with new cloth.) (Fig.12)

4. RA Filter cleaning:
Remove the RA Filter.(Fig.11) And Vacuum-clean. (Fig.13)
After cleaning, replace the RA Filter.

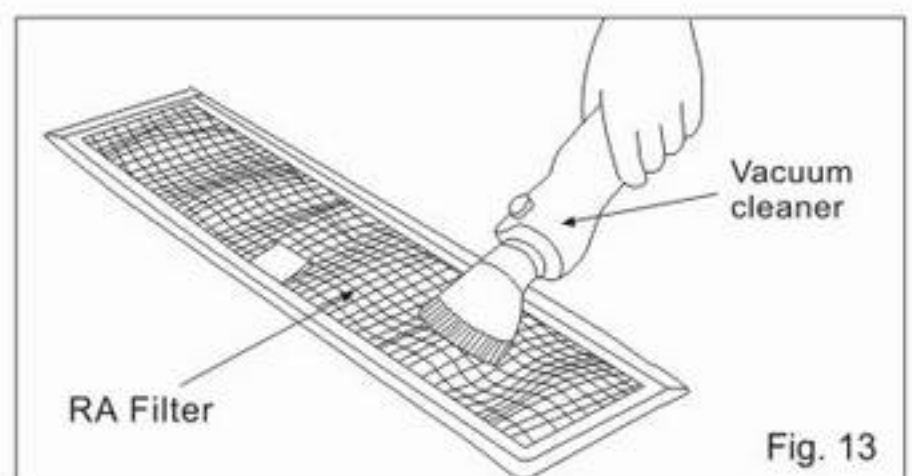
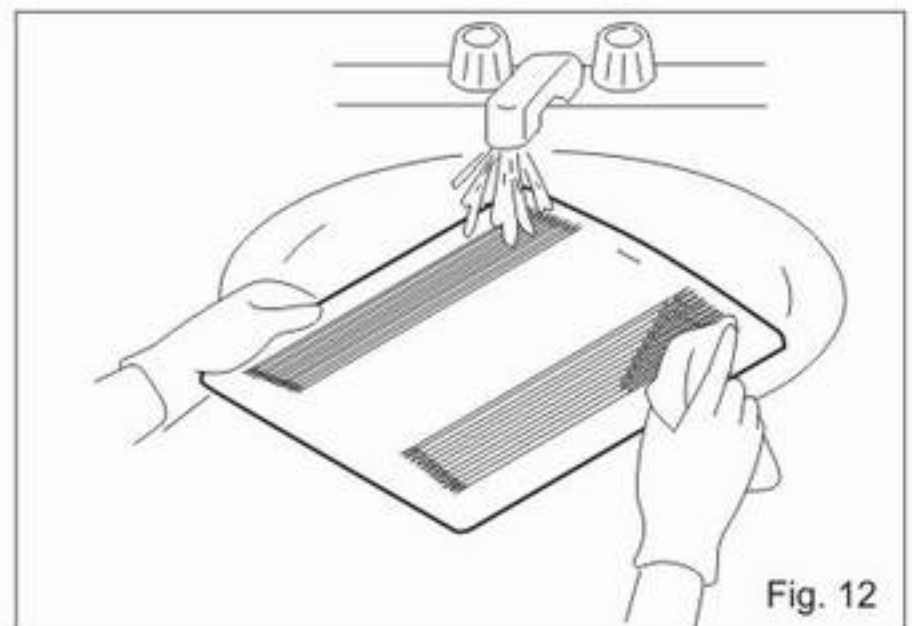
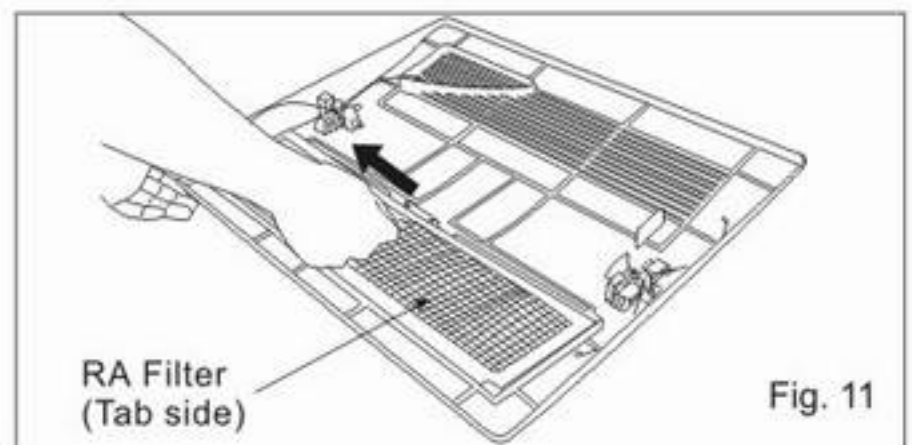
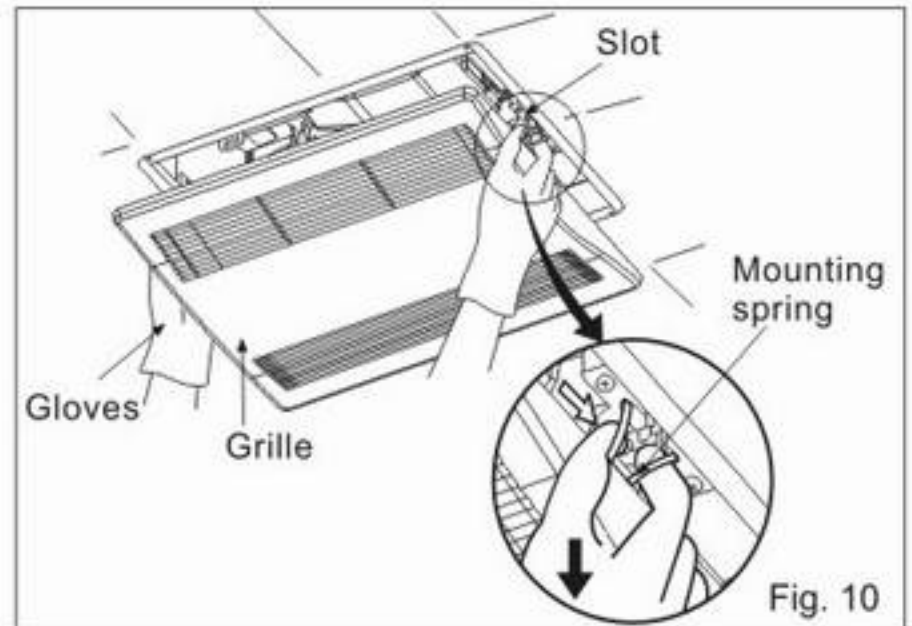
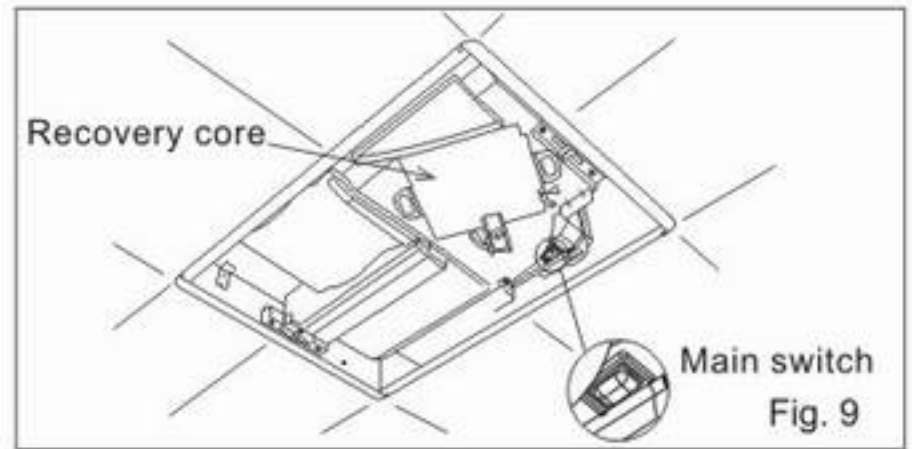

MAINTENANCE (CLEANING) CONTINUED

5. OA Filter cleaning:

Remove the OA Filter.(Fig.14) And Vacuum-clean, wash softly within warm water with non-abrasive neutral detergent and allow to air dry. (Fig.15)

After cleaning, replace the OA Filter according to Filter direction on Fig.14. Make sure the OA Filter has been installed securely.

The filter can only be installed in one direction.

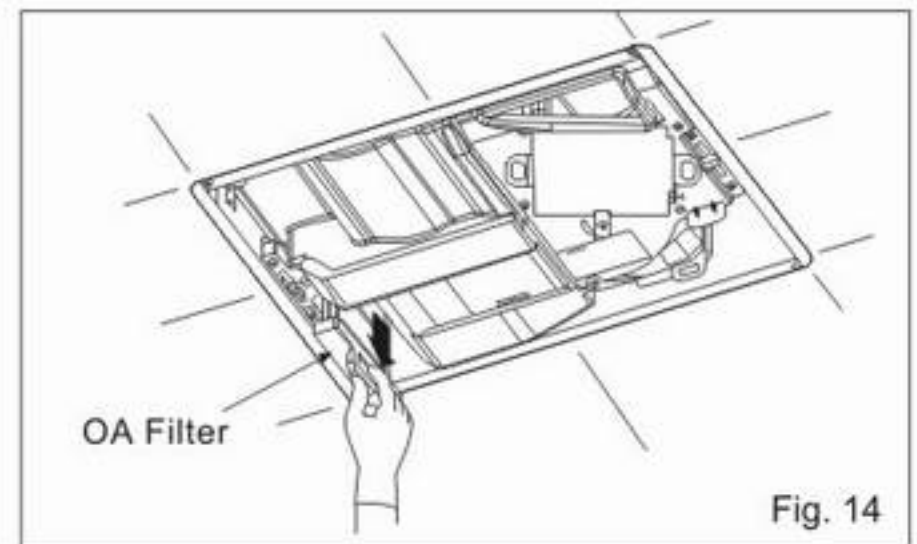

CAUTION:

Be careful when removing the filter in case condensation water and/or dust has accumulated and may fall out.

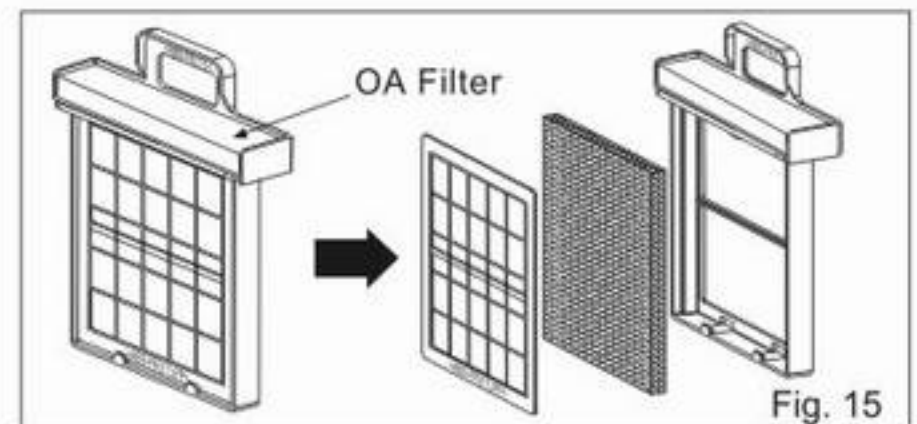

6. Remove dust and dirt from fan body using a vacuum cleaner. (Fig 16)

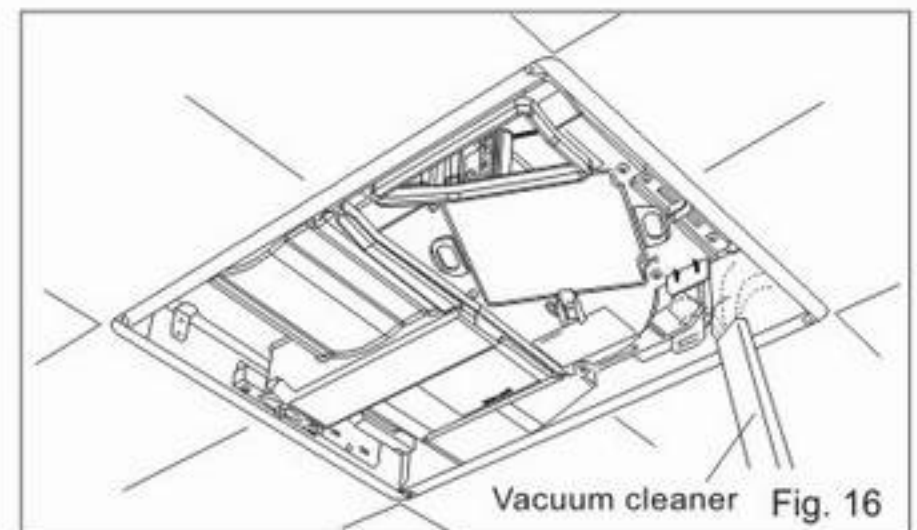

7. Element cleaning:

- ① Turn the knob to the right.(Fig.17)
- ② Rise up the handles.(Fig.18)
- ③ Pull the Recovery core straight down, and slowly remove. (Fig.18)

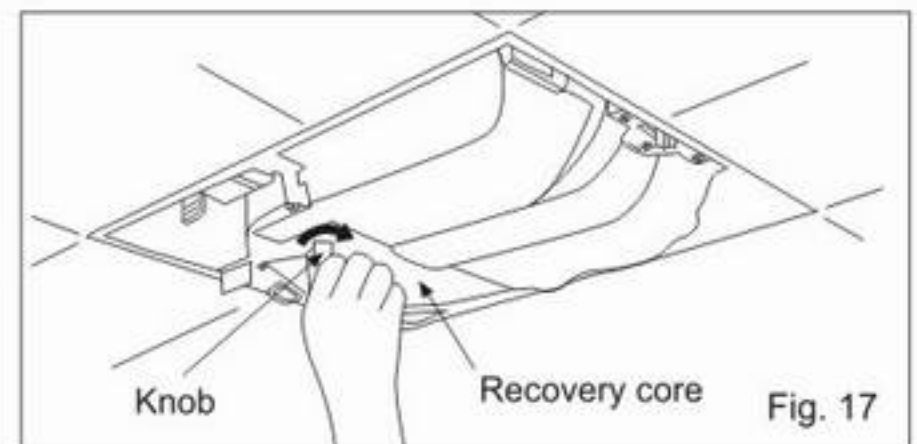

CAUTION:

Be careful when removing the filter in case condensation water and/or dust has accumulated and may fall out.

