S U P P L Y I N G C L E A N A I R T O I N D U S T R Y

MODEL PORTA AIR™ Portable Cartridge System



The new Porta Air™ Portable Cartridge System is a manually cleaned media air cleaner for use in intermittent duty source capture applications in industry. The Porta Air™ captures airborne contaminants such as welding smoke, grinding dust, plastic dust and other fine particles.



For further information:
BERRIMAN ASSOCIATES
1-800-480-3630
www.berriman.com

PORTA AIR™ FEATURES & SPECIFICATIONS

Principles of Operation:

Airborne contaminants enter the Porta Air through the hood/arm assembly at a rate of 1100 cubic feet of air per minute (cfm). Heavy particles are propelled downward through the venturi and into the clean out trays. Small submicron particles are then trapped within the pleats of the two 99.8% efficient cartridge filters. The cleaned air is then gently diffused out the bottom of the unit. Replace filters when the differential pressure gage indicates that the cartridge filters are dirty.

SPECIFICATIONS:

DIMENSIONS:	46" H x 28.5" W x 37" D
WEIGHT:	Approx. weight 375 lbs. shipping
ARM ASSEMBLY:	11' long x 8" diameter. Externally supported arm with full 360° arm rotation. Arm assembly incorporated a gas spring which provides easy up and down movement.
HOOD:	18 ga aluminum hood with handle. Hood moves easily vertically and horizontally.
AIR FLOW VOLUME:	1000 CFM.
MOTOR:	1.5 HP, thermally protected.
BLOWER:	Direct drive, backward incline, 3450 RPM.
CABINET CONSTRUCTION:	16 Ga. welded galvanized steel.
CONTROLS:	All models include control circuitry and thermal protection.
POWER:	120V/60 hz/14 amp max. or 208-240V/60 hz/8 amp max. Ten foot power cord with molded plug standard on single phase models.
CASTERS:	Two large 8" diameter semi-pneumatic (front) wheels and two heavy duty swivel casters (back).
FINISH:	Durable powder coat paint.
FILTRATION:	Two high efficiency cartridge filters, 12 ³ / ₄ " diameter x 22". 382 sq. ft. total. 99.8% efficient at .5 micron.
FILTER ACCESS:	Hinged side door.
FILTER GAGE:	Dwyer Minihelic II; indicates pressure up to 10" H2O.
NOISE LEVEL:	73 dBA at 6'.
WARRANTY:	Limited three year warranty.

STANDARD FEATURES:

- Air volume – 1000 cfm.
- Externally supported 11'1" arm. Full 360° rotation.
- 1.5 horse power motor.
- 382 square feet of filter media.
- 99.8% efficient at .5 micron.
- Large 8" diameter front wheels.
- Quiet operation.
- Three year limited warranty.

OPTIONAL FEATURES:

- Halogen light.
- Double arm configuration.
- 2nd stage HEPA filter.

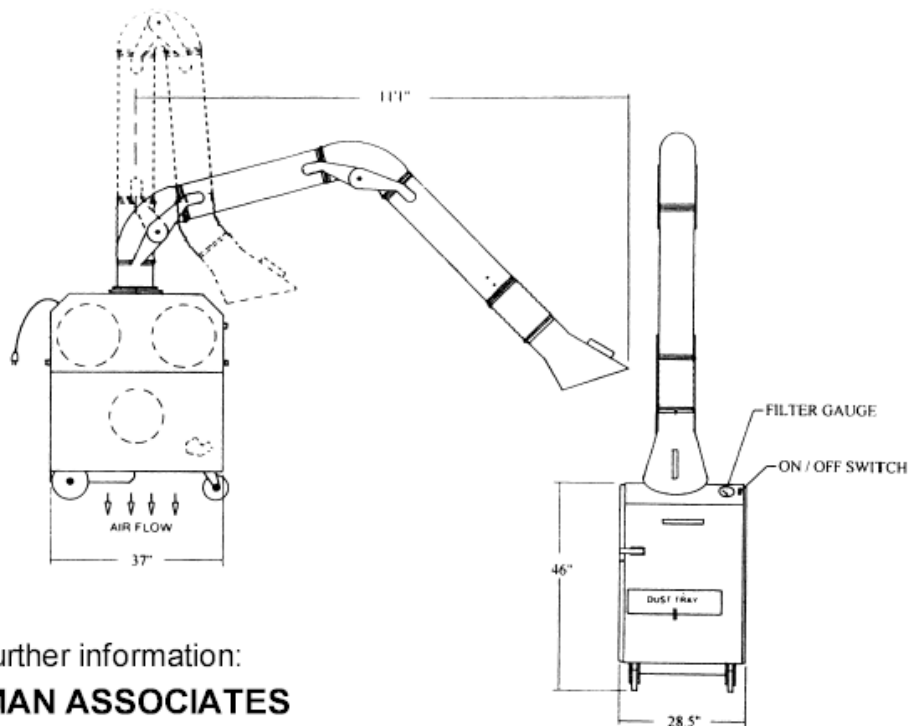

For further information:
BERRIMAN ASSOCIATES
1-800-480-3630
www.berriman.com

